

Product Data Sheet 4114 N/2H4

ebmpapst

The engineer's choice



4114 N/2H4

INDEX

1	General	3
2	Mechanics	3
2.1	General.....	3
2.2	Connections.....	3
3	Operating Data	4
3.1	Electrical Operating Data	4
3.2	Electrical Interface - Output.....	5
3.3	Electrical Features.....	6
3.4	Aerodynamics.....	7
3.5	Sound Data.....	8
4	Environment	8
4.1	General.....	8
4.2	Climatic Requirements	8
4.3	EMC.....	8
5	Safety	10
5.1	Electrical Safety.....	10
5.2	Approval Tests	10
6	Reliability	10
6.1	General.....	10

1 General

Fan type	Fan	
Rotating direction looking at rotor	Clockwise	
Airflow direction	Air intake over struts	
Bearing system	Ball bearing	
Mounting position - shaft	Any	

2 Mechanics

2.1 General

Width	119,0 mm	
Height	119,0 mm	
Depth	38,0 mm	
Mass	0,390 kg	
Housing material	Metal	
Impeller material	Plastic	
Max. torque when mounted across both mounting flanges	Wire outlet corner: 420 Ncm Remaining corners: 560 Ncm	
Screw size	ISO 4762 - M4 degreased, without an additional brace and without washer	

2.2 Connections

Electrical connection	Wires	
Lead wire length	L = 310 mm	
Tolerance	+/- 10,0 mm	

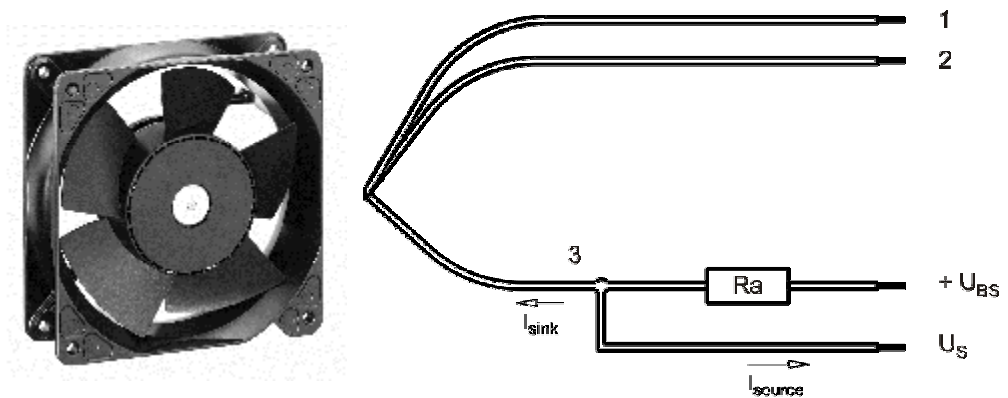

Wire	Color	Operation	Wire size	Insulation diameter
1	red	+ UB	AWG 22	1,7 mm
2	blue	- GND	AWG 22	1,7 mm
3	white	Tacho	AWG 22	1,7 mm

The auxiliaries shown on the schematic diagram (which are required for the intended use) are not part of our delivery.

3 Operating Data

3.1 Electrical Operating Data

Measurement conditions: Normal air density = 1,2 kg/m³; Temperature 23°C +/- 3°C; Motor axis horizontal; warm-up time before measuring 5 minutes (unless otherwise specified). In the intake and outlet area should not be any solid obstruction within 0,5 m.

$\Delta p = 0$: corresp. to free air flow (see chapter aerodynamics)
I: corresp. to arithm. mean current value

Note:

No inrush current at Unom means:

The internal electrolytic capacitor 120uF/50V has no resistor or inrush current limitation, essentially the power supply and the type and length of the connecting cable is limiting the Inrush current.

Features	Condition	Symbol	Values		
Voltage range		U	16 V		30 V
Nominal voltage		U_N		24 V	
Power consumption	$\Delta p = 0$	P	15,2 W	30 W	30,0 W
Tolerance	0010		+/- 15 %	+/- 15 %	+/- 15 %
Current consumption	$\Delta p = 0$	I	950 mA	1.250 mA	1.000 mA
Tolerance	0010		+/- 15 %	+/- 15 %	+/- 15 %
Speed	$\Delta p = 0$	n	5.400 1/min	6.800 1/min	6.800 1/min
Tolerance	0010		+/- 10 %	+/- 10 %	+/- 10 %
Starting current consumption				3.200 mA	

3.2 Electrical Interface - Output

Tacho type	/2 (open collector)
------------	---------------------

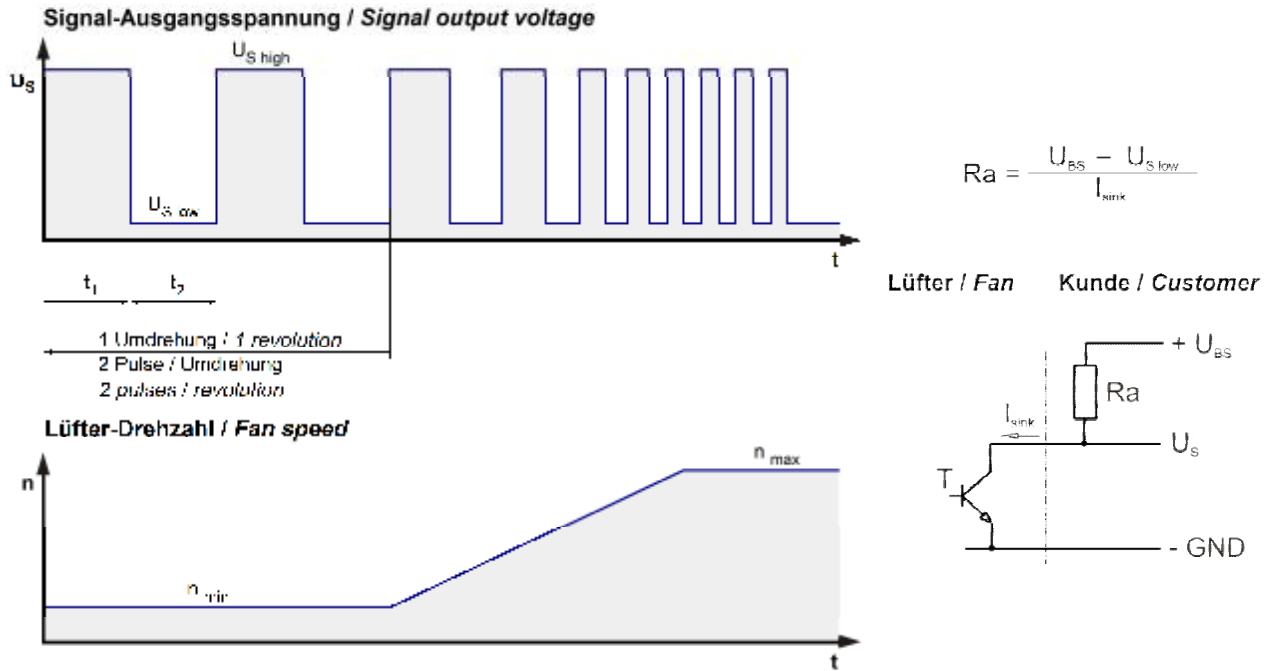

Features	Note	Values
Tacho operating voltage	U_{BS}	60 V
Tacho signal Low	$U_{S,low}$	$I_{sink}: 2 \text{ mA}$ $\leq 0,5 \text{ V}$
Tacho signal High	$U_{S,high}$	$I_{source}: 0 \text{ mA}$ 60 V
Maximum sink current	I_{sink}	$\leq 10 \text{ mA}$
External resistor	External resistor R_a from U_{BS} to U_S required. All voltages measured to GND.	
Tacho frequency	$(2 \times n) / 60$	
Tacho isolated from motor	No	

n = revolutions per minute (1/min)

3.3 Electrical Features

Electronic function	Speed-Controlled	
Reversed polarity protection	Rectifying diode	
Max. residual current at U_N	$I_F \leq 10 \text{ mA}$	
Locked rotor protection	Auto restart	
Locked rotor current at U_N	I_{block} approx. 3.200 mA	
Clock signal at locked rotor	t_3 / t_4 typical: 1,0 s / 5,5 s	

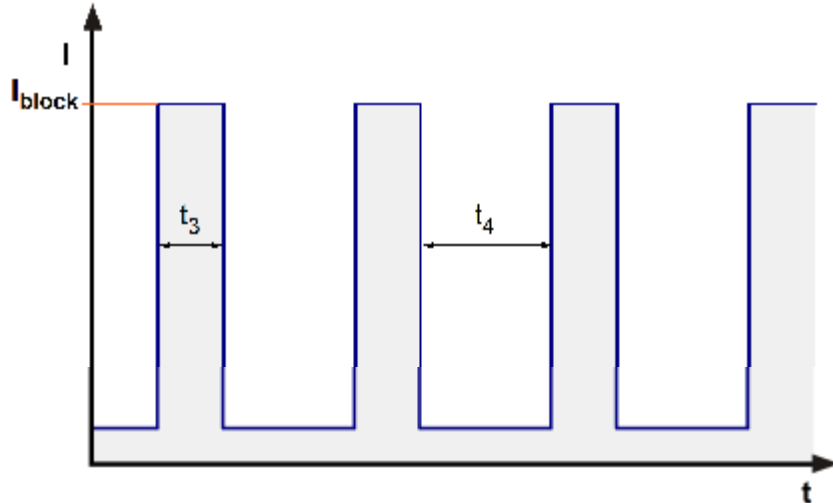

Internal Fuse:

Littlefuse NANO2(R) FUSE; Very fast acting 451 Series; 3 A (Art.-Nr.: 451003)

3.4 Aerodynamics

Measurement conditions: Measured with a double chamber intake rig acc. to DIN EN ISO 5801.
 Normal air density = 1,2 kg/m³; Temperature 23°C +/- 3°C;
 In the intake and outlet area should not be any solid obstruction within 0,5 m. Motor shaft horizontal.
 The information is only valid under the specified test conditions and may be changed by the installation conditions. If there are deviations from the standard test conditions, the characteristic values must be checked under the installed conditions.

a.) Operation condition:

6.800 1/min at free air flow		
Max. free-air flow ($\Delta p = 0 / \dot{V} = \text{max.}$)	350,0 m ³ /h	
Max. static pressure ($\Delta p = \text{max.} / \dot{V} = 0$)	400 Pa	

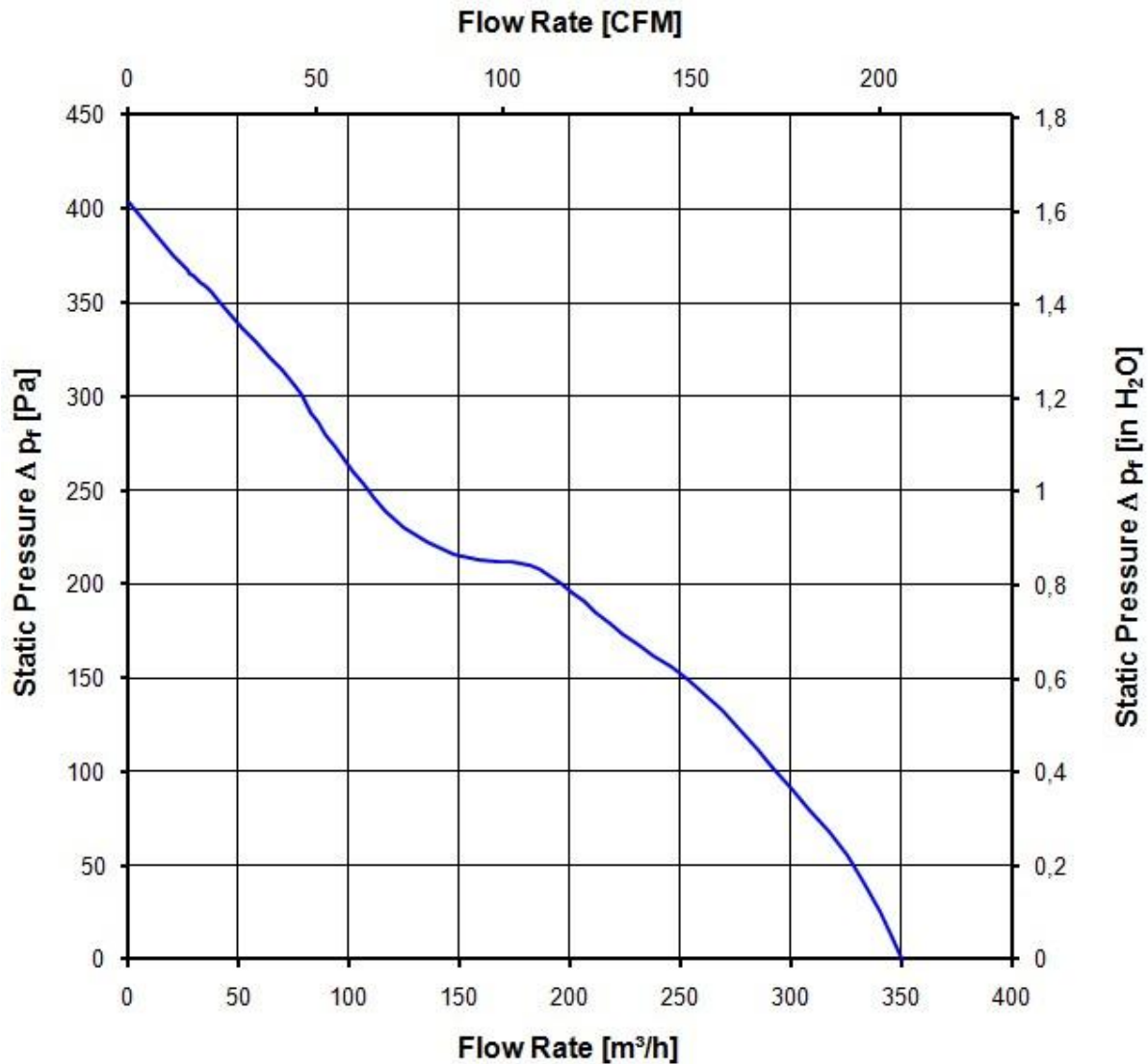

3.5 Sound Data

Measurement conditions: Sound pressure level: 1 meter distance between microphone and the air intake.
 Sound power level: Acc. to DIN 45635 part 38 (ISO 10302)
 Measured in a semianchoic chamber with a background noise level of $L_p(A) < 5 \text{ dB(A)}$
 For further measurement conditions see chapter aerodynamics.

a.) Operation condition:

6.800 1/min at free air flow		
Optimal operating point	250,0 m3/h @ 140 Pa	
Sound power level at the optimal operating point	7,4 bel(A)	
Sound pressure level at free air flow, measured in rubber bands	67,0 dB(A)	

4 Environment

4.1 General

Min. permitted ambient temperature TU min.	-20 °C	
Max. permitted ambient temperature TU max.	65 °C	
Min. permitted storage temperature TL min.	-40 °C	
Max. permitted storage temperature TL max.	80 °C	

4.2 Climatic Requirements

Humidity requirements	humid heat, constant; according to DIN EN 60068-2-78, 14 days	
Water exposure	None	
Dust requirements	None	
Salt fog requirements	None	

Permitted application area:

The product is intended for use in sheltered rooms with controlled temperature and controlled humidity. Directly exposure to water must be avoided.

Pollution degree 1 (according DIN EN 60664-1)

There is either no pollution or it occurs only dry, non-conductive pollution. The pollution has no negative impact.

Please require severity levels and specification parameters from the responsible development departments.

4.3 EMC

Kind	Radiated Emission; 30 MHz - 1000 MHz
According	DIN EN 55022:2007-04
Check accuracy / Limit	Class B
Result	Below limit Class B

Kind	Electrostatic Discharge Immunity Test
-------------	--

Accordinging	DIN EN 61000-4-2:2001-12
Check accuracy / Limit	Contact Discharge +/- 4 kV; Air Discharge +/- 8 kV
Result	B: The monitored function may deviate from designed performance to a specified level during exposure to a disturbance or revert to a fail safe mode or operation, but shall return to normal operation after the disturbance is removed.

5 Safety

5.1 Electrical Safety

Dielectric strength DIN EN 60950 (VDE 0805) and DIN EN 60335 (VDE 0700) A.) Type test Measuring conditions: After 48h of storage at 95% R.H. and 25°C. No arcing or breakdown is allowed! All connections together to ground. B.) Routine test Measuring conditions: At indoor climate. No arcing or breakdown is allowed! All connections together to ground.	500 VAC / 1 Min. 850 VDC / 1 Sec.	
Isolation resistance Measuring conditions: After 48h of storage at 95% R.H. and 25°C measured with U=500 VDC for 1 min.	RI > 10 MOhm	
Clearance / creepage distance	1,0 mm / 1,2 mm	
Protection class	III	

5.2 Approval Tests

CE	EC Declaration of Conformity	Yes
EAC	Eurasian Conformity	Yes
UL	Underwriters Laboratories	Yes / UL507, Electric Fans
VDE	Association for Electrical, Electronic and Information Technologies	Yes / Approval acc. to EN 60950 (VDE 0805) - Information technology equipment
CSA	Canadian Standards Association	Yes / C22.2 No. 113 Fans and Ventilators
CCC	China Compulsory Certification	Not applicable

The approval tests are observed to:

U approval max.:30,0 V @ TU approval max.: 65,0 °C

6 Reliability

6.1 General

Life expectancy L10 at TU = 40 °C	62.500 h	
Life expectancy L10 at TU max.	35.000 h	
Life expectancy L10 acc. to IPC 9591 at TU = 40 °C	105.000 h	

Copyright of the drawings, sketches, technical notes and/or components of the machine, theme, etc. is reserved. All rights are reserved. In the event of the grant of a patent or the registration of a utility model or design.

Stahlgewicht nach DIN ISO 668 beachten!
Refer to technical notice DIN ISO 668!

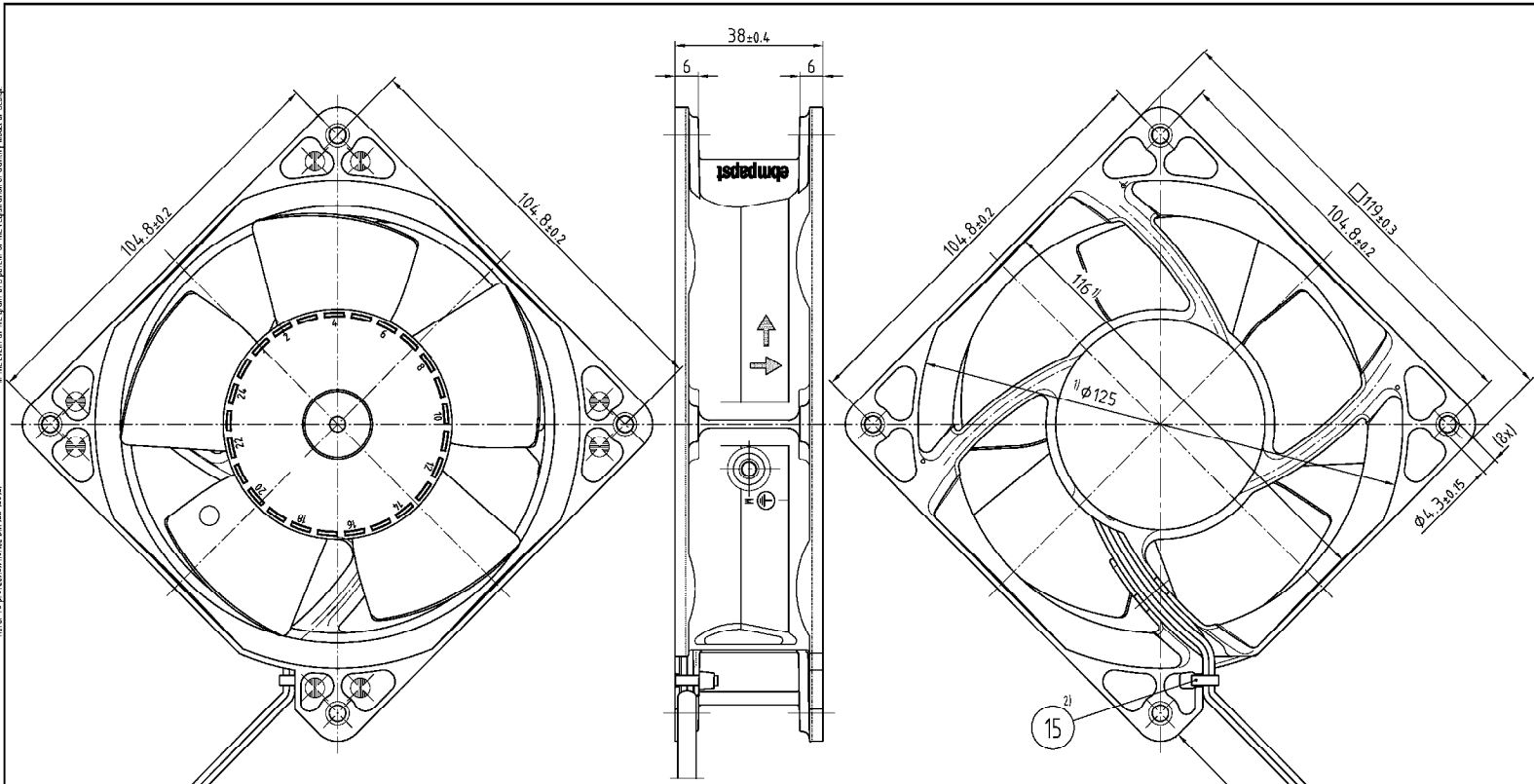

- 1) = Maße für Montagewand
- Axialspiel bei Kugellagerung (K): 0 (durch Federausgleich)
- Axialspiel bei Gleitlagerung (G): 0,1 bis 0,6
- 2) = Mit Handhabungswerkzeug montiert,
Kopf darf nach Montage nicht über Außenkontur des Lüftergehäuses stehen

- 1) = Measures for prefab wall
- Axial play with ball bearing (K): 0 (by spring compensation)
- Axial play with sleeve bearing (G): 0,1 to 0,6
- 2) = With handling tool installed,
Head may not stand over outer contour of the fan housing after assembly

Leitungslänge siehe Produktspezifikation
For conduit length see product specification

SAP-Status/State	Änd. Nr./Change No.	AxiCAD-System-Version	ebmpapst	Werkstoff/Material:	Volumen/Volume (mm ³)
		CAD-Umgebung/ CAD-Environment			Gewicht/Mass (g)
		Änder/Date	Name/Name	Artikel/Title	
Tolerierung/Tolerances:		Recht / Drawn		axial compact fan	
Allgemeintoleranzen/Gen. Tolerances:		Gepr. / Checked		Zchg.-Nr./Drawing-No.:	
DIN ISO 2768-1 u. 2-mK		Freig. / Released		Ers./Zchg./Replaces:	
		ebmpapst			
		Datum/Type of Document	Teilenummer/Part/No.	Index/Box	Formel/Size
		ebm-papst St. Leonen GmbH & Co. KG			Missel/Scale