

Product Data Sheet 4184 NXHH

ebmpapst

The engineer's choice



4184 NXHH

INDEX

1	General	3
2	Mechanics	3
2.1	General	3
2.2	Connections	3
3	Operating Data	4
3.1	Electrical Operating Data	4
3.2	Electrical Features	4
3.3	Aerodynamics	6
3.4	Sound Data	7
4	Environment.....	7
4.1	General	7
4.2	Climatic Requirements.....	7
4.3	EMC	7
5	Safety.....	9
5.1	Electrical Safety	9
5.2	Approval Tests	9
6	Reliability.....	9
6.1	General	9

1 General

Fan type	Fan	
Rotating direction looking at rotor	Clockwise	
Airflow direction	Air intake over struts	
Bearing system	Ball bearing	
Mounting position - shaft	Any	

2 Mechanics

2.1 General

Width	119,0 mm	
Height	119,0 mm	
Depth	38,0 mm	
Mass	0,380 kg	
Housing material	Metal	
Impeller material	Plastic	
Max. torque when mounted across both mounting flanges Screw size	Wire outlet corner: 170 Ncm Remaining corners: 300 Ncm ISO 4762 - M3 degreased, without an additional brace and without washer	

2.2 Connections

Electrical connection	Plug	
Lead wire length	See drawing	
Tolerance		
Plug	See drawing	
Contact	See drawing	



3 Operating Data

3.1 Electrical Operating Data

Measurement conditions: Normal air density = 1,2 kg/m³; Temperature 23°C +/- 3°C; Motor axis horizontal; warm-up time before measuring 5 minutes (unless otherwise specified). In the intake and outlet area should not be any solid obstruction within 0,5 m.

$\Delta p = 0$: corresp. to free air flow (see chapter aerodynamics)
 I: corresp. to arithm. mean current value

Features	Condition	Symbol	Values		
Voltage range		U	12 V		25 V
Nominal voltage		U_N		24 V	
Power consumption	$\Delta p = 0$	P	2,9 W	12 W	15 W
Tolerance	0010		+/- 17,5 %	+/- 12,5 %	+/- 15 %
Current consumption	$\Delta p = 0$	I	240 mA	508 mA	590 mA
Tolerance	0010		+/- 17,5 %	+/- 12,5 %	+/- 15 %
Speed	$\Delta p = 0$	n	2.800 1/min	4.900 1/min	5.100 1/min
Tolerance	0010		+/- 12,5 %	+/- 7,5 %	+/- 10 %
Starting current consumption				2.870 mA	

3.2 Electrical Features

Electronic function	None	
Reversed polarity protection	Rectifying diode	
Max. residual current at U_N	$I_F \leq 20 \mu A$	
Locked rotor protection	Auto restart	
Locked rotor current at U_N	I_{block} approx. 2.870 mA	
Clock signal at locked rotor	t_3 / t_4 typical: 0,3 s / 1,6 s	

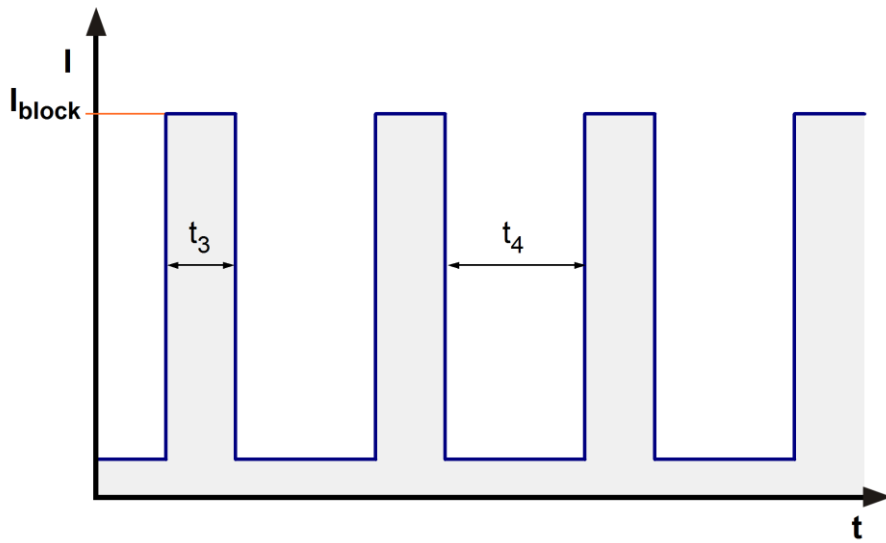

3.3 Aerodynamics

Measurement conditions: Measured with a double chamber intake rig acc. to DIN EN ISO 5801.
 Normal air density = 1,2 kg/m³; Temperature 23°C +/- 3°C;
 In the intake and outlet area should not be any solid obstruction within 0,5 m. Motor shaft horizontal.
 The information is only valid under the specified test conditions and may be changed by the installation conditions. If there are deviations from the standard test conditions, the characteristic values must be checked under the installed conditions.

a.) Operation condition:

4.900 1/min at free air flow

Max. free-air flow ($\Delta p = 0 / \dot{V} = \text{max.}$)	260,0 m ³ /h	
Max. static pressure ($\Delta p = \text{max.} / \dot{V} = 0$)	204 Pa	

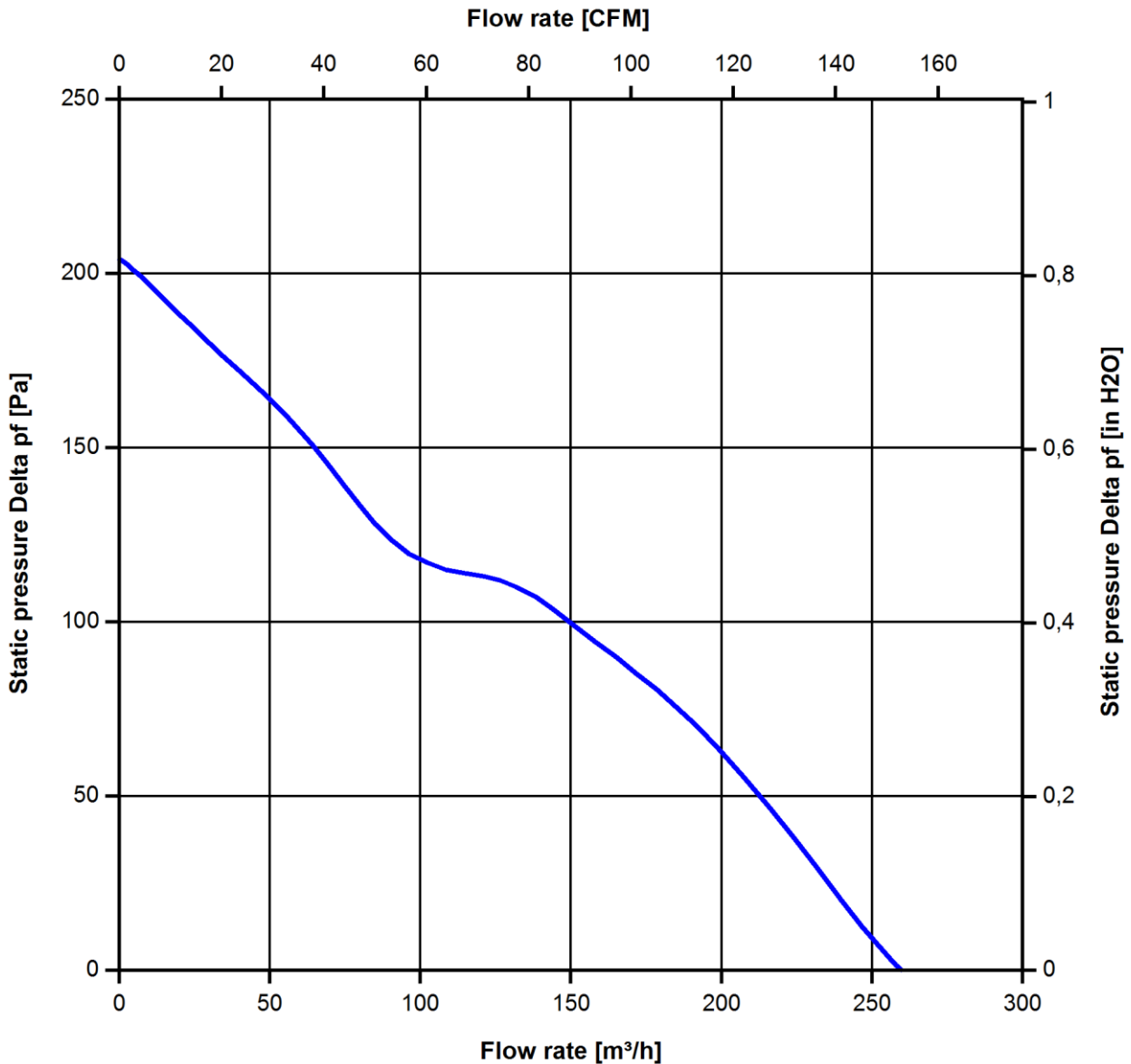

3.4 Sound Data

Measurement conditions: Sound pressure level: 1 meter distance between microphone and the air intake.
 Sound power level: Acc. to DIN 45635 part 38 (ISO 10302)
 Measured in a semianchoic chamber with a background noise level of $L_p(A) < 5 \text{ dB(A)}$
 For further measurement conditions see chapter aerodynamics.

a.) Operation condition:

4.900 1/min at free air flow

Optimal operating point	160,0 m ³ /h @ 100 Pa	
Sound power level at the optimal operating point	6,7 bel(A)	
Sound pressure level at free air flow, measured in rubber bands	60,0 dB(A)	

4 Environment

4.1 General

Min. permitted ambient temperature TU min.	-30 °C	
Max. permitted ambient temperature TU max.	55 °C	
Min. permitted storage temperature TL min.	-40 °C	
Max. permitted storage temperature TL max.	80 °C	

4.2 Climatic Requirements

Humidity requirements	humid heat, constant; according to DIN EN 60068-2-78, 14 days	
Water exposure	None	
Dust requirements	None	
Salt fog requirements	None	

Permitted application area:

The product is intended for use in sheltered rooms with controlled temperature and controlled humidity. Directly exposure to water must be avoided.

Pollution degree 1 (according DIN EN 60664-1)

There is either no pollution or it occurs only dry, non-conductive pollution. The pollution has no negative impact.

Please require severity levels and specification parameters from the responsible development departments.

4.3 EMC

Kind	Radiated Emission; 30 MHz - 1000 MHz
According	DIN EN 55022:2007-04
Check accuracy / Limit	Class B
Result	Below limit Class B

Kind	Electrostatic Discharge Immunity Test
According	DIN EN 61000-4-2:2001-12
Check accuracy / Limit	Contact Discharge +/- 4 kV; Air Discharge +/- 8 kV

Result	A: The monitored function operates as designed during and after exposure to a disturbance.
--------	--------------------------------------------------------------------------------------------

5 Safety

5.1 Electrical Safety

Dielectric strength DIN EN 60950 (VDE 0805) and DIN EN 60335 (VDE 0700) A.) Type test Measuring conditions: After 48h of storage at 95% R.H. and 25°C. No arcing or breakdown is allowed! All connections together to ground.	500 VAC / 1 Min.	
B.) Routine test Measuring conditions: At indoor climate. No arcing or breakdown is allowed! All connections together to ground.	850 VDC / 1 Sec.	
Isolation resistance Measuring conditions: After 48h of storage at 95% R.H. and 25°C measured with U=500 VDC for 1 min.	RI > 10 MOhm	
Clearance / creepage distance	1,0 mm / 1,2 mm	
Protection class	III	

5.2 Approval Tests

CE	EC Declaration of Conformity	Yes
EAC	Eurasian Conformity	Yes
UL	Underwriters Laboratories	Yes / UL507, Electric Fans
VDE	Association for Electrical, Electronic and Information Technologies	Yes / Approval acc. to EN 60950 (VDE 0805) - Information technology equipment
CSA	Canadian Standards Association	Yes / C22.2 No. 113 Fans and Ventilators
CCC	China Compulsory Certification	Not applicable

The approval tests are observed to:

U approval max.: 25,0 V @ TU approval max.: 55,0 °C

6 Reliability

6.1 General

Life expectancy L10 at TU = 40 °C	70.000 h	
Life expectancy L10 at TU max.	50.000 h	
Life expectancy L10 acc. to IPC 9591 at TU = 40 °C	117.500 h	

Copying of this document and using it in whole or in part, and the use or reproduction of the contents hereof are forbidden without express permission. Offences are liable to the payment of damages. All rights are reserved in the event of the grant of a patent, or the registration of a utility model or design.

Schutzvermerk nach DIN ISO 9016 beachten!
Refer to protection notice DIN ISO 9016!

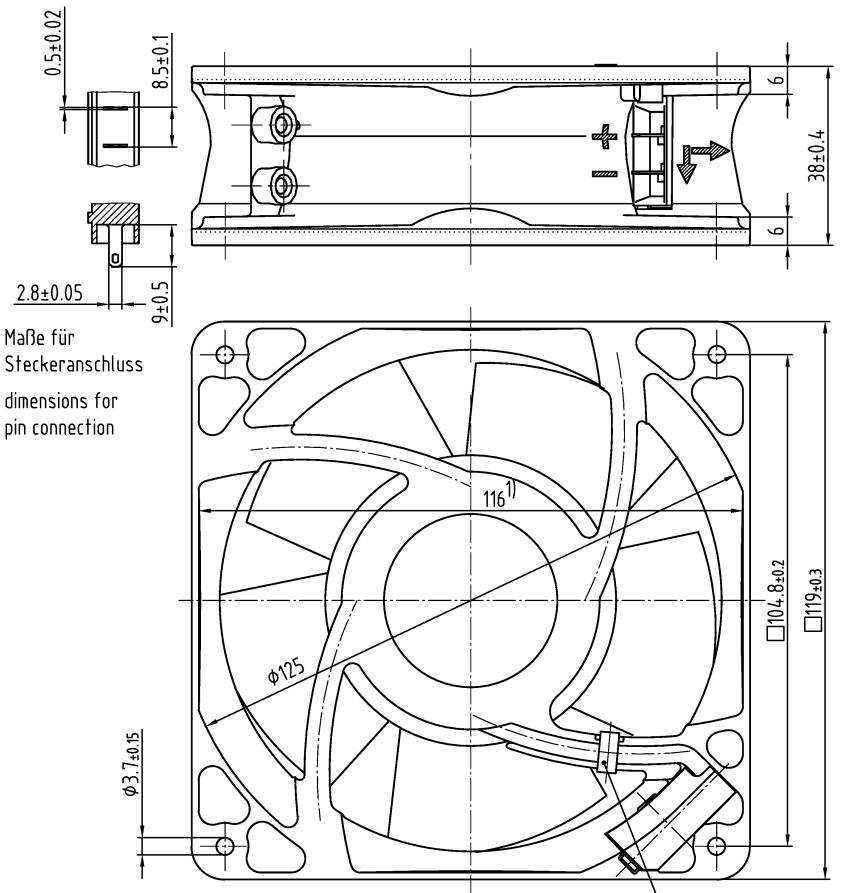

Maße für Steckeranschluss
dimensions for pin connection

- 1) Maße für Montagewand 1) dimensions for assembly wall
2) wenn in Stückliste enthalten 2) only if included in bill of material
- Axialspiel bei axial clearance by
 - Kugellagerung (K): 0 (mit Federausgleich) - ball bearing (K): 0 (with spring compensation)
 - Gleitlagerung (G): 0.1 - 0.6 - sleeve bearing (G): 0.1 - 0.6

SAP-Status/State		AutocAD-System-Version		ebmpapst		Werkstoff/Material		Volumen/Volume (mm ³):	
Änd.-Nr./Change-No.		Date/Date		CAD-Umgebung/ CAD-Environment				Gewicht/Mass (g):	
Tolerierung/Tolerances:		Bearb./ Drawn		Name/Name		Artikel/Title			
Allgemeintoleranzen/Gen. tolerances:		Gepr./ Checked				Zchg.-Nr./ Drawing.-No.:		Ers.f.Zchg./ Replaces:	
		Freig./ Released.				ebmpapst			
				ebm-papst St. Georgen GmbH & Co. KG		Dokumenttyp/Type of Document		Formal/Size: Masstab/scale	
						Teildokument (Blatt/Page)		Index/Index	
						F			