

Product Data Sheet 4314/17T-192

**ebmpapst**

The engineer's choice



4314/17T-192

**INDEX**

<b>1</b>	<b>General</b> .....	<b>3</b>
<b>2</b>	<b>Mechanics</b> .....	<b>3</b>
2.1	General.....	3
2.2	Connections.....	3
<b>3</b>	<b>Operating Data</b> .....	<b>4</b>
3.1	Electrical Interface - Input.....	4
3.2	Electrical Operating Data .....	5
3.3	Electrical Interface - Output.....	6
3.4	Electrical Features.....	7
3.5	Aerodynamics.....	8
3.6	Sound Data.....	9
<b>4</b>	<b>Environment</b> .....	<b>9</b>
4.1	General.....	9
4.2	Climatic Requirements .....	9
<b>5</b>	<b>Safety</b> .....	<b>10</b>
5.1	Electrical Safety.....	10
5.2	Approval Tests .....	10
<b>6</b>	<b>Reliability</b> .....	<b>10</b>
6.1	General.....	10

## 1 General

Fan type	Fan	
Rotating direction looking at rotor	Clockwise	
Airflow direction	Air outlet over struts	
Bearing system	Ball bearing	
Mounting position - shaft	Any	

## 2 Mechanics

### 2.1 General

Width	119,0 mm	
Height	119,0 mm	
Depth	32,0 mm	
Mass	0,220 kg	
Housing material	Plastic	
Impeller material	Plastic	
Max. torque when mounted across both mounting flanges	Wire outlet corner: 20 Ncm Remaining corners: 20 Ncm	
Screw size	ISO 4762 - M4 degreased, without an additional brace and without washer	

### 2.2 Connections

Electrical connection	Wires	
Lead wire length	L = 310 mm	
Tolerance	+/- 10,0 mm	
Wire size (AWG)	24	
Insulation diameter	1,55 mm	

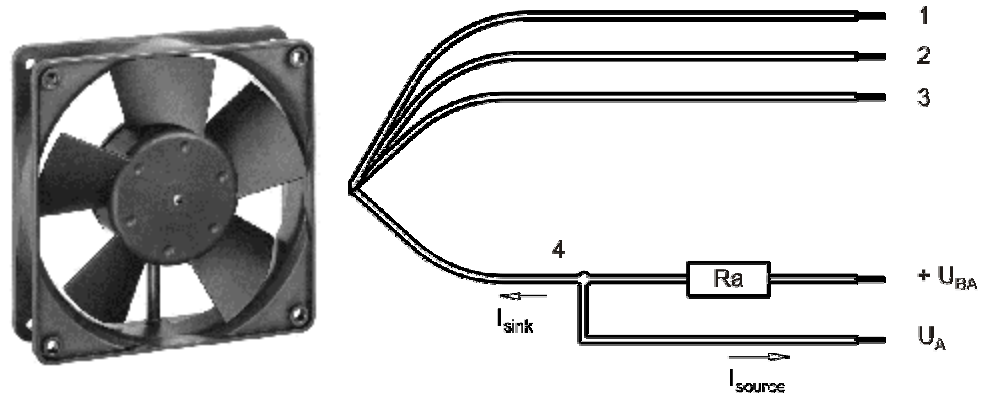

Wire	Color	Operation
1	red	+ UB
2	blue	- GND
3	violet	NTC
4	white	Alarm

The auxiliaries shown on the schematic diagram (which are required for the intended use) are not part of our delivery.

### 3 Operating Data

#### 3.1 Electrical Interface - Input

Control input	External Temperature Sensor
---------------	-----------------------------

#### Features

<p><b>Characteristics</b></p>	<table border="1"> <caption>Graph Data: Drehzahl / speed [1/min] vs Umgebungstemperatur / Ambient temperature [°C]</caption> <thead> <tr> <th>Umgebungstemperatur [°C]</th> <th>Drehzahl / speed [1/min]</th> </tr> </thead> <tbody> <tr><td>-20</td><td>1400</td></tr> <tr><td>-15</td><td>1400</td></tr> <tr><td>-10</td><td>1400</td></tr> <tr><td>-5</td><td>1400</td></tr> <tr><td>0</td><td>1400</td></tr> <tr><td>5</td><td>1400</td></tr> <tr><td>10</td><td>1400</td></tr> <tr><td>15</td><td>1400</td></tr> <tr><td>20</td><td>1400</td></tr> <tr><td>25</td><td>1400</td></tr> <tr><td>30</td><td>1400</td></tr> <tr><td>35</td><td>1733</td></tr> <tr><td>40</td><td>2067</td></tr> <tr><td>45</td><td>2400</td></tr> <tr><td>50</td><td>2800</td></tr> <tr><td>55</td><td>2800</td></tr> <tr><td>60</td><td>2800</td></tr> <tr><td>65</td><td>2800</td></tr> </tbody> </table>	Umgebungstemperatur [°C]	Drehzahl / speed [1/min]	-20	1400	-15	1400	-10	1400	-5	1400	0	1400	5	1400	10	1400	15	1400	20	1400	25	1400	30	1400	35	1733	40	2067	45	2400	50	2800	55	2800	60	2800	65	2800
Umgebungstemperatur [°C]	Drehzahl / speed [1/min]																																						
-20	1400																																						
-15	1400																																						
-10	1400																																						
-5	1400																																						
0	1400																																						
5	1400																																						
10	1400																																						
15	1400																																						
20	1400																																						
25	1400																																						
30	1400																																						
35	1733																																						
40	2067																																						
45	2400																																						
50	2800																																						
55	2800																																						
60	2800																																						
65	2800																																						
<p><b>Schematics</b></p>	<p>The schematic diagram illustrates the electrical interface between the fan and the customer's control system. On the left, the fan is shown with a central terminal 'C'. On the right, the customer's circuit includes a +UB supply line, an internal reference (Interne Ref. / Interna ref.) connected to the fan's 'C' terminal, an input terminal (Eingang / Input) connected to the fan's 'C' terminal through a resistor, an NTC sensor connected to the input terminal, and a -GND ground connection.</p>																																						

### 3.2 Electrical Operating Data

Measurement conditions: Normal air density = 1,2 kg/m<sup>3</sup>; Temperature 23°C +/- 3°C; Motor axis horizontal; warm-up time before measuring 5 minutes (unless otherwise specified). In the intake and outlet area should not be any solid obstruction within 0,5 m.

$\Delta p = 0$ : corresp. to free air flow (see chapter aerodynamics)  
 I: corresp. to arithm. mean current value

Name	Condition		
TU 0001	TU: $\geq 50$ °C		
NTC 0001	NTC $\leq 34$ kOhm		

Features	Condition	Symbol	Values		
Voltage range		U	18 V		28 V
Nominal voltage		$U_N$		24 V	
Power consumption	$\Delta p = 0$	P	2,9 W	4,8 W	5,8 W
Tolerance	TU / NTC 0010		+/- 25 %	+/- 25 %	+/- 25 %
Current consumption	$\Delta p = 0$	I	160 mA	200 mA	180 mA
Tolerance	TU / NTC 0010		+/- 25 %	+/- 25 %	+/- 25 %
Speed	$\Delta p = 0$	n	2.250 1/min	2.800 1/min	2.800 1/min
Tolerance	TU / NTC 0010		+/- 12,5 %	+/- 9 %	+/- 9 %
Starting current consumption				780 mA	

3.3 Electrical Interface - Output

Alarm type	/17 (high = ok, open collector)
------------	---------------------------------

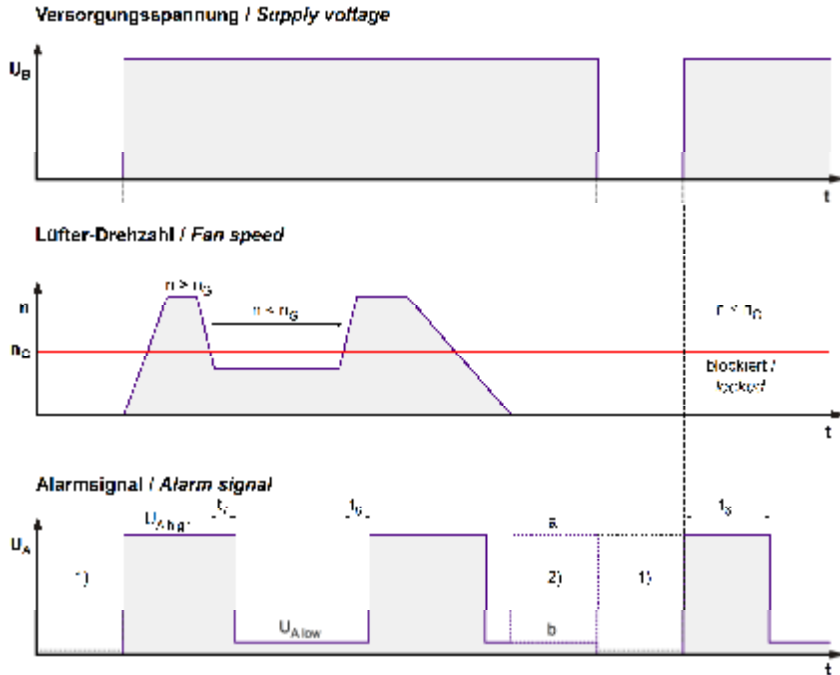

$$R_a = \frac{U_{BA} - U_{A,low}}{I_{sink}}$$

Lüfter / Fan      Kunde / Customer

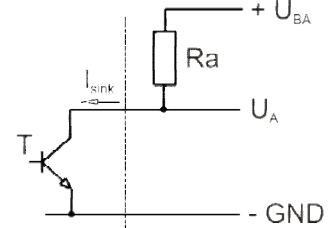

1) Wenn der Lüfter abgeschaltet ist, hängt der Zustand des Ausgangssignals  $U_A$  von der Kundenapplikation ab.  
 When the fan is powered off, the output signal  $U_A$  depends on the customer's application.  
 2) Für den gültigen Zustand (a oder b) siehe Alarmunterbrechung in der Tabelle.  
 For the valid condition (a or b) see alarm suppression in the table.

Features	Note	Values
Alarm operating voltage	$U_{BA}$	$\leq 60 \text{ V}$
Alarm signal Low	$U_{A,low}$	$I_{sink}: 2 \text{ mA}$ $\leq 0,4 \text{ V}$
Alarm signal High	$U_{A,high}$	$I_{source}: 0 \text{ mA}$ $60 \text{ V}$
Maximum sink current	$I_{sink}$	$\leq 20 \text{ mA}$
External resistor	External resistor $R_a$ from $U_{BA}$ to $U_A$ required. All voltage measured to GND.	
Alarm start-up delay time	$t_6$	$\leq 15 \text{ s}$
Alarm trip speed limit	$n_G$	$1.150 \text{ 1/min}$ $\pm 100 \text{ 1/min}$
Tolerance		
Alarm at sense failure	Yes	
Alarm latch	No	
Alarm isolated from motor	No	

### 3.4 Electrical Features

Electronic function	Speed-Controlled	
Reversed polarity protection	Rectifying diode	
Max. residual current at $U_N$	$I_F \leq 20 \text{ mA}$	
Locked rotor protection	Auto restart	
Locked rotor current at $U_N$	$I_{\text{block}}$ approx. 780 mA	
Clock signal at locked rotor	$t_3 / t_4$ typical: 0,6 s / 10 s	

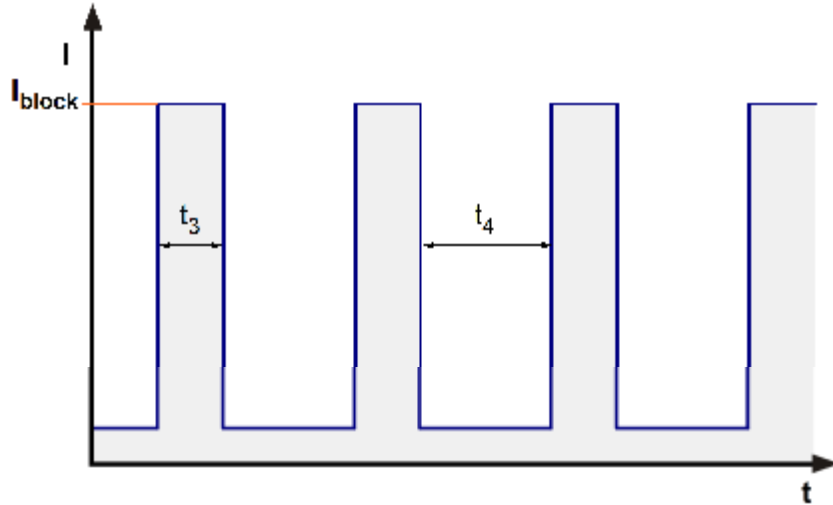

### 3.5 Aerodynamics

Measurement conditions: Measured with a double chamber intake rig acc. to DIN EN ISO 5801.  
 Normal air density = 1,2 kg/m<sup>3</sup>; Temperature 23°C +/- 3°C;  
 In the intake and outlet area should not be any solid obstruction within 0,5 m. Motor shaft horizontal.  
 The information is only valid under the specified test conditions and may be changed by the installation conditions. If there are deviations from the standard test conditions, the characteristic values must be checked under the installed conditions.

a.) Operation condition:

2.800 1/min at free air flow	TU >= 50 °C NTC <= 34 kOhm		
------------------------------	-------------------------------	--	--

Max. free-air flow ( $\Delta p = 0 / \dot{V} = \text{max.}$ )	170,0 m <sup>3</sup> /h	
Max. static pressure ( $\Delta p = \text{max.} / \dot{V} = 0$ )	78 Pa	

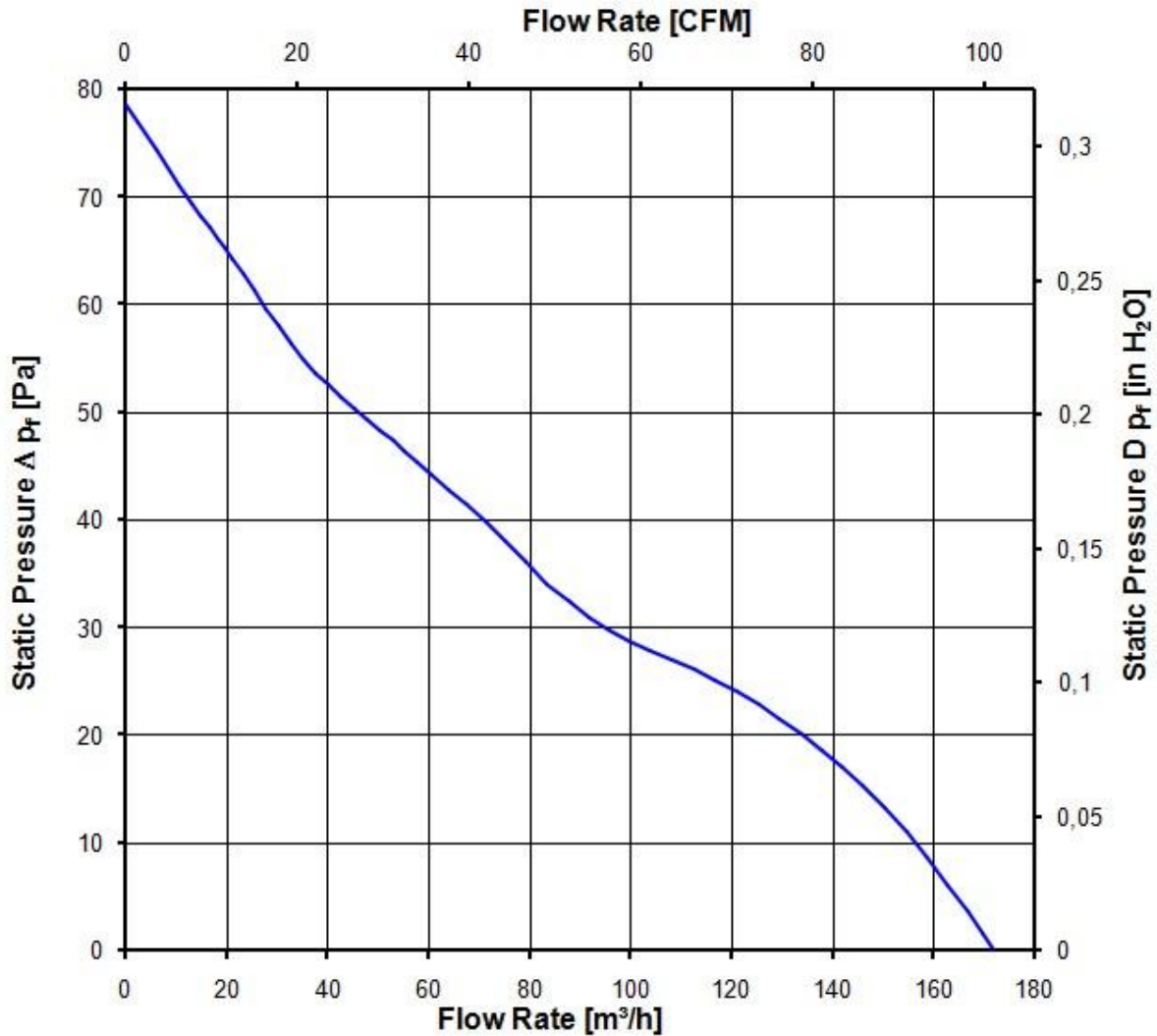



### 3.6 Sound Data

Measurement conditions: Sound pressure level: 1 meter distance between microphone and the air intake.  
 Sound power level: Acc. to DIN 45635 part 38 (ISO 10302)  
 Measured in a semianchoic chamber with a background noise level of  $L_p(A) < 5 \text{ dB(A)}$   
 For further measurement conditions see chapter aerodynamics.

a.) Operation condition:

2.800 1/min at free air flow	TU $\geq 50 \text{ }^\circ\text{C}$ NTC $\leq 34 \text{ k}\Omega$		
------------------------------	--	--	--

Optimal operating point	134,0 m <sup>3</sup> /h @ 17 Pa		
Sound power level at the optimal operating point	5,8 bel(A)		
Sound pressure level at free air flow, measured in rubber bands	45,0 dB(A)		

## 4 Environment

### 4.1 General

Min. permitted ambient temperature TU min.	-20 °C		
Max. permitted ambient temperature TU max.	65 °C		
Min. permitted storage temperature TL min.	-40 °C		
Max. permitted storage temperature TL max.	80 °C		

### 4.2 Climatic Requirements

Humidity requirements	humid heat, constant; according to DIN EN 60068-2-78, 14 days		
Water exposure	None		
Dust requirements	None		
Salt fog requirements	None		

Permitted application area:

The product is intended for use in sheltered rooms with controlled temperature and controlled humidity. Directly exposure to water must be avoided.

Pollution degree 1 (according DIN EN 60664-1)

There is either no pollution or it occurs only dry, non-conductive pollution. The pollution has no negative impact.

Please require severity levels and specification parameters from the responsible development departments.

## 5 Safety

### 5.1 Electrical Safety

Dielectric strength DIN EN 60950 (VDE 0805) and DIN EN 60335 (VDE 0700) A.) Type test Measuring conditions: After 48h of storage at 95% R.H. and 25°C. No arcing or breakdown is allowed! All connections together to ground. B.) Routine test Measuring conditions: At indoor climate. No arcing or breakdown is allowed! All connections together to ground.	500 VAC / 1 Min.  850 VDC / 1 Sec.	
Isolation resistance Measuring conditions: After 48h of storage at 95% R.H. and 25°C measured with U=500 VDC for 1 min.	RI > 10 MOhm	
Clearance / creepage distance	1,0 mm / 1,2 mm	
Protection class	III	

### 5.2 Approval Tests

CE	EC Declaration of Conformity	Yes
EAC	Eurasian Conformity	Yes
UL	Underwriters Laboratories	Yes / UL507, Electric Fans
VDE	Association for Electrical, Electronic and Information Technologies	Yes / Approval acc. to EN 60950 (VDE 0805) - Information technology equipment
CSA	Canadian Standards Association	Yes / C22.2 No. 113 Fans and Ventilators
CCC	China Compulsory Certification	Not applicable

The approval tests are observed to:

U approval max.: 28 V @ TU approval max.: 65 °C

## 6 Reliability

### 6.1 General

Life expectancy L10 at TU = 40 °C	65.000 h	
Life expectancy L10 at TU max.	35.000 h	
Life expectancy L10 acc. to IPC 9591 at TU = 40 °C	110.000 h	

Anzahl und Länge der Litzen  
siehe Produktspezifikation /  
Length and number of wires  
see design specification.

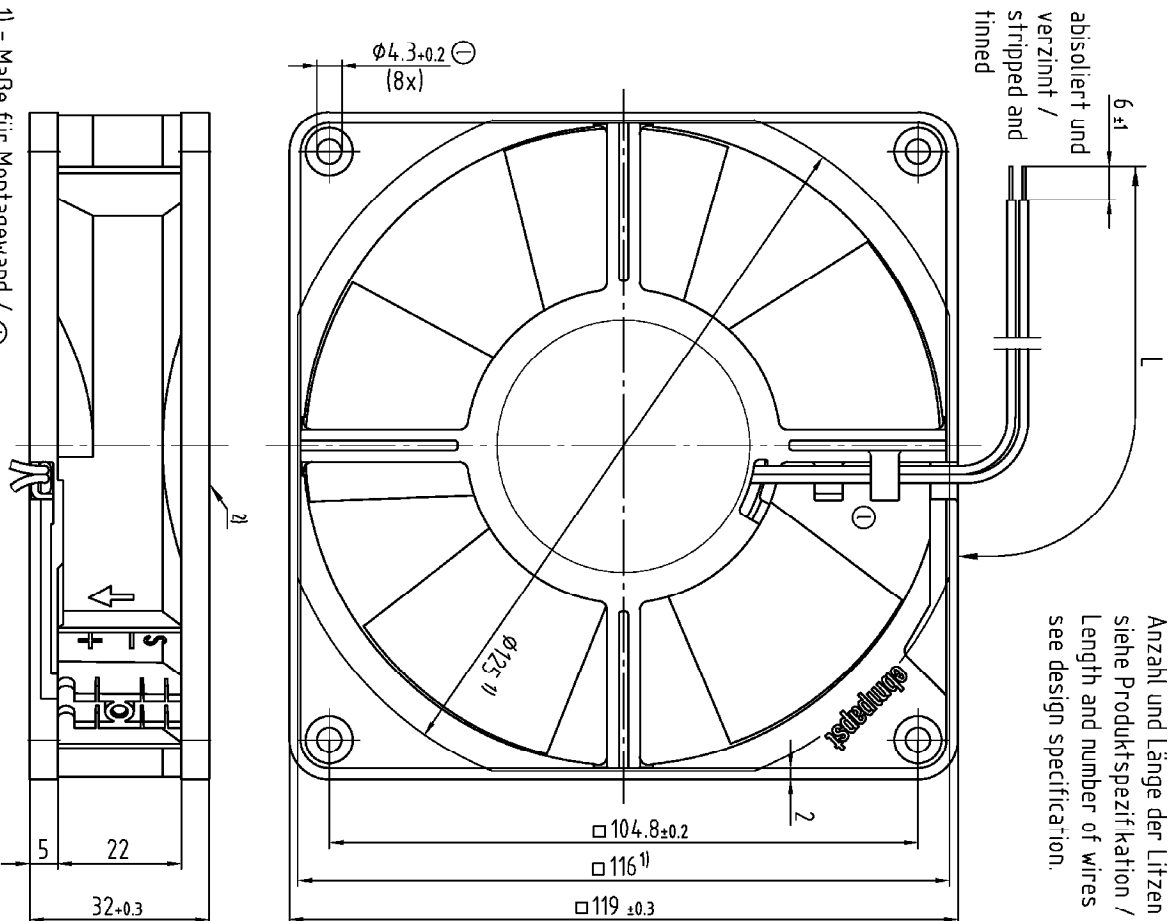

1) = Maße für Montagewand / ①  
Dimensions for assembly wall  
2) = Rotorüberstand bis max. 0.4 mm zulässig /  
Rotor excess length max. 0.4 mm allowable

SAP-Status/State	Artik.-Nr./Change-No.	Handl.-Spezial-Version CAB-ET-Verfahren	ehm-papst F&E-Untersuchung/ CAD-Entwickler	Verstärker/Material	Volume/Volume (cm <sup>3</sup> ):
		Datum/Date	Name/Name	Artikel/Title	Gewicht/Mass (g):
Toleranz-/olerances:	Beart./ Drawn	Gepr./ Checked	Freig./ Released	Zchg.-Nr./ Drawing-No.:	Est./Zug-/Released:
Allgemeinmaßen/Gen. tolerances:	<b>ehm-papst</b>			Dokumenttyp./Type of Document:	Inter./Index
	ehm-papst St. Georgen GmbH & Co. KG			Teilskizze (Blatt/Prage)	Formal/Size
					Massstab/scale