

Product Data Sheet 622/2H3P

**ebmpapst**

The engineer's choice



## 622/2H3P

## INDEX

|          |                                    |           |
|----------|------------------------------------|-----------|
| <b>1</b> | <b>General</b> .....               | <b>3</b>  |
| <b>2</b> | <b>Mechanics</b> .....             | <b>3</b>  |
| 2.1      | General.....                       | 3         |
| 2.2      | Connections.....                   | 3         |
| <b>3</b> | <b>Operating Data</b> .....        | <b>4</b>  |
| 3.1      | Electrical Interface - Input.....  | 4         |
| 3.2      | Electrical Operating Data .....    | 5         |
| 3.3      | Electrical Interface - Output..... | 6         |
| 3.4      | Electrical Features.....           | 7         |
| 3.5      | Aerodynamics.....                  | 8         |
| 3.6      | Sound Data.....                    | 9         |
| <b>4</b> | <b>Environment</b> .....           | <b>9</b>  |
| 4.1      | General.....                       | 9         |
| 4.2      | Climatic Requirements .....        | 9         |
| <b>5</b> | <b>Safety</b> .....                | <b>10</b> |
| 5.1      | Electrical Safety.....             | 10        |
| 5.2      | Approval Tests .....               | 10        |
| <b>6</b> | <b>Reliability</b> .....           | <b>10</b> |
| 6.1      | General.....                       | 10        |

## 1 General

|                                     |                        |  |
|-------------------------------------|------------------------|--|
| Fan type                            | Fan                    |  |
| Rotating direction looking at rotor | Clockwise              |  |
| Airflow direction                   | Air outlet over struts |  |
| Bearing system                      | Ball bearing           |  |
| Mounting position - shaft           | Any                    |  |

## 2 Mechanics

### 2.1 General

|   |   |  |
|---|---|--|
| Width   | 60,0 mm   |  |
| Height  | 60,0 mm   |  |
| Depth   | 25,0 mm   |  |
| Mass  | 0,070 kg  |  |
| Housing material                                      | Plastic   |  |
| Impeller material                                     | Plastic   |  |
| Max. torque when mounted across both mounting flanges | Wire outlet corner: 10 Ncm<br>Remaining corners: 20 Ncm                 |  |
| Screw size  | ISO 4762 - M3 degreased, without an additional brace and without washer |  |

### 2.2 Connections

|                       |            |  |
|-----------------------|------------|--|
| Electrical connection | Wires      |  |
| Lead wire length      | L = 310 mm |  |
| Tolerance             | + - 10 mm  |  |
| Wire size (AWG)       | 24         |  |
| Insulation diameter   | 1,5 mm     |  |

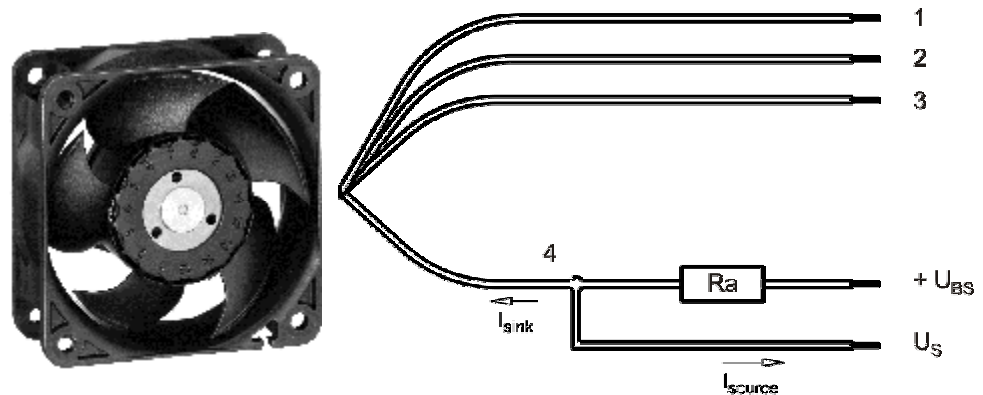

| Wire | Color  | Operation |
|------|--------|-----------|
| 1    | red    | + UB      |
| 2    | blue   | - GND     |
| 3    | violet | PWM       |
| 4    | white  | Tacho     |

The auxiliaries shown on the schematic diagram (which are required for the intended use) are not part of our delivery.

### 3 Operating Data

#### 3.1 Electrical Interface - Input

|               |     |
|---------------|-----|
| Control input | PWM |
|---------------|-----|

#### Features

|                 |                |                |
|-----------------|----------------|----------------|
| Input type      | Open collector |                |
| PWM - Frequency |                | 1 kHz - 30 kHz |

|                               |  |
|-------------------------------|--|
| <p><b>Characteristics</b></p> |  |
| <p><b>Schematics</b></p>      |  |

### 3.2 Electrical Operating Data

Measurement conditions: Normal air density = 1,2 kg/m<sup>3</sup>; Temperature 23°C +/- 3°C; Motor axis horizontal; warm-up time before measuring 5 minutes (unless otherwise specified). In the intake and outlet area should not be any solid obstruction within 0,5 m.

$\Delta p = 0$ : corresp. to free air flow (see chapter aerodynamics)  
 I: corresp. to arithm. mean current value

| Name     | Condition    |
|----------|--------------|
| PWM 0001 | PWM: > 90 %; |

| Features                     | Condition      | Symbol | Values      |             |             |
|------------------------------|----------------|--------|-------------|-------------|-------------|
| Voltage range                |                | U      | 8 V         |             | 15 V        |
| Nominal voltage              |                | $U_N$  |             | 12 V        |             |
| Power consumption            | $\Delta p = 0$ | P      | 2,65 W      | 5,5 W       | 5,8 W       |
| Tolerance                    | PWM 0010       |        | +/- 17,5 %  | +/- 17,5 %  | +/- 17,5 %  |
| Current consumption          | $\Delta p = 0$ | I      | 330 mA      | 460 mA      | 385 mA      |
| Tolerance                    | PWM 0010       |        | +/- 17,5 %  | +/- 17,5 %  | +/- 17,5 %  |
| Speed                        | $\Delta p = 0$ | n      | 7.450 1/min | 9.700 1/min | 9.700 1/min |
| Tolerance                    | PWM 0010       |        | **)         | **)         | **)         |
| Starting current consumption |                |        |             | 1.450 mA    |             |

### 3.3 Electrical Interface - Output

|            |                     |
|------------|---------------------|
| Tacho type | /2 (open collector) |
|------------|---------------------|

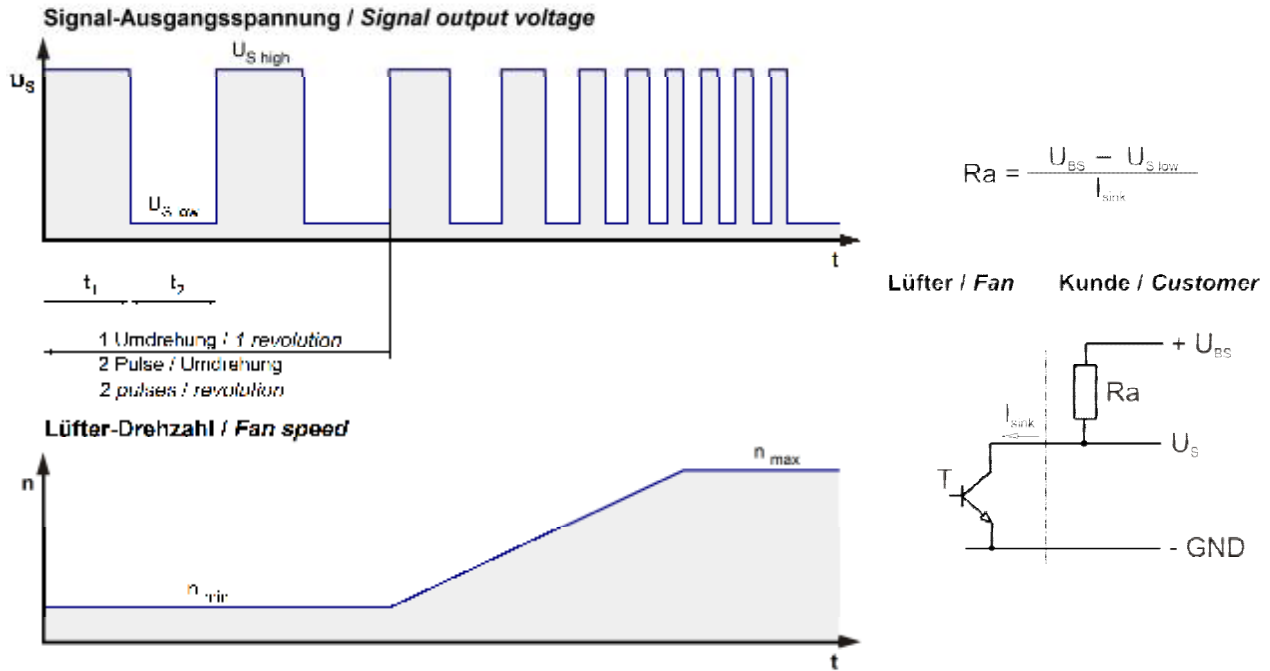

| Features                  | Note   | Values                           |
|---------------------------|--|----------------------------------|
| Tacho operating voltage   | $U_{BS}$   | $\leq 60$ V                      |
| Tacho signal Low          | $U_{S,low}$  | $I_{sink}: 2$ mA<br>$\leq 0,4$ V |
| Tacho signal High         | $U_{S,high}$   | $I_{source}: 0$ mA<br>60 V       |
| Maximum sink current      | $I_{sink}$   | $\leq 4$ mA                      |
| External resistor         | External resistor $R_a$ from $U_{BS}$ to $U_S$ required. All voltages measured to GND. |                                  |
| Tacho frequency           | $(2 \times n) / 60$  |                                  |
| Tacho isolated from motor | No   |                                  |
| Slew rate                 |  | $\Rightarrow 0,5$ V/us           |

$n$  = revolutions per minute (1/min)

### 3.4 Electrical Features

|                                |                                     |  |
|--------------------------------|-------------------------------------|--|
| Electronic function            | Speed-Controlled                    |  |
| Reversed polarity protection   | Rectifying diode                    |  |
| Max. residual current at $U_N$ | $I_F \leq 700 \mu\text{A}$          |  |
| Locked rotor protection        | Auto restart                        |  |
| Locked rotor current at $U_N$  | $I_{\text{block}}$ approx. 1.450 mA |  |
| Clock signal at locked rotor   | $t_3 / t_4$ typical: 0,5 s / 10 s   |  |

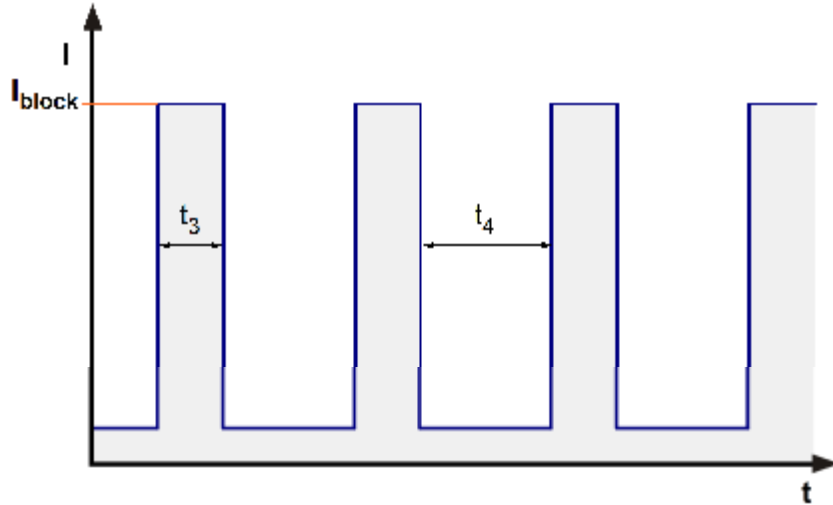

**3.5 Aerodynamics**

Measurement conditions: Measured with a double chamber intake rig acc. to DIN EN ISO 5801.  
 Normal air density = 1,2 kg/m<sup>3</sup>; Temperature 23°C +/- 3°C;  
 In the intake and outlet area should not be any solid obstruction within 0,5 m. Motor shaft horizontal.  
 The information is only valid under the specified test conditions and may be changed by the installation conditions. If there are deviations from the standard test conditions, the characteristic values must be checked under the installed conditions.

a.) Operation condition:

|                              |             |  |  |
|------------------------------|-------------|--|--|
| 9.700 1/min at free air flow | PWM > 90 %; |  |  |
|------------------------------|-------------|--|--|

|   |                        |  |
|---|------------------------|--|
| Max. free-air flow ( $\Delta p = 0 / \dot{V} = \text{max.}$ )   | 67,0 m <sup>3</sup> /h |  |
| Max. static pressure ( $\Delta p = \text{max.} / \dot{V} = 0$ ) | 200 Pa                 |  |

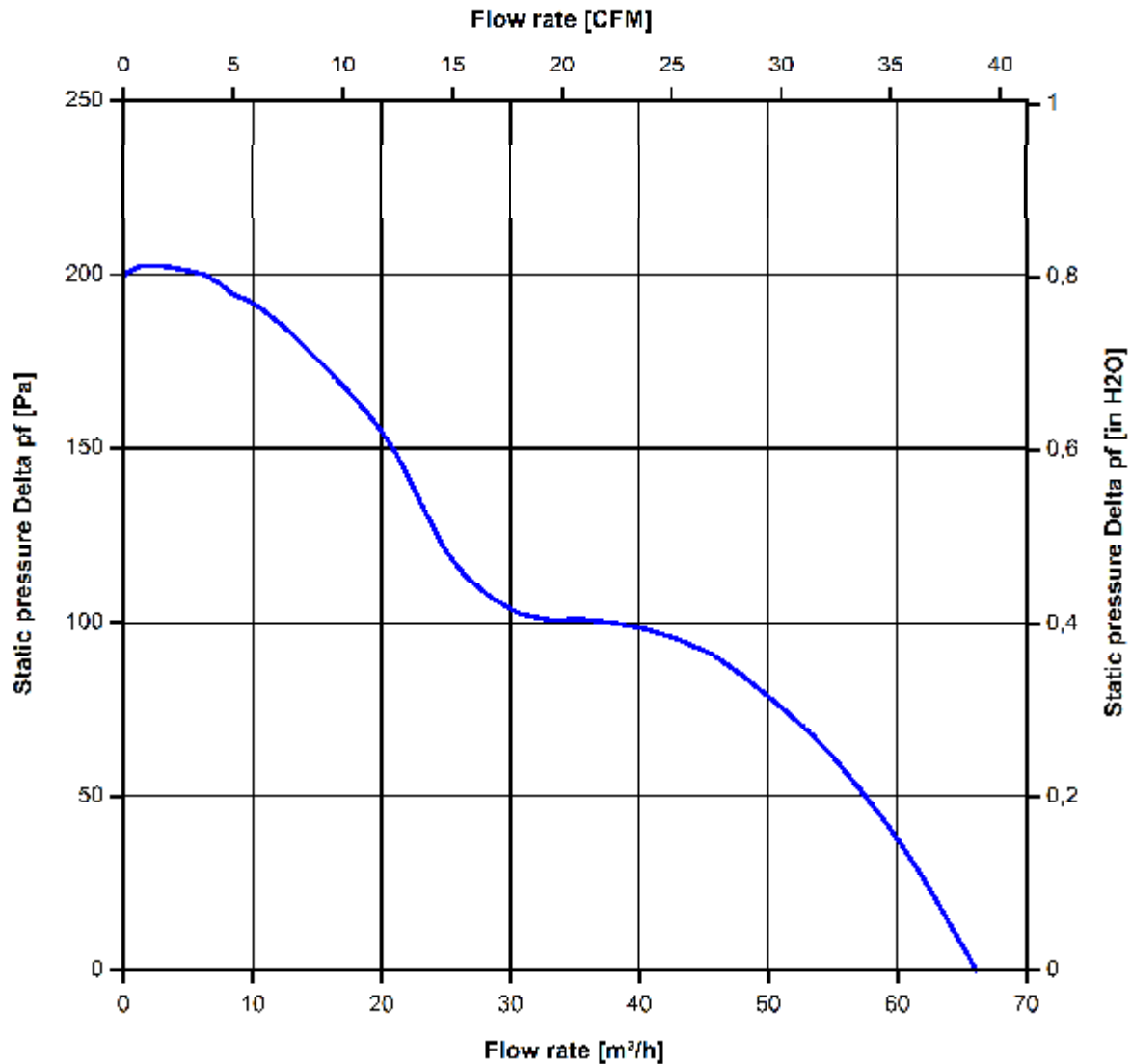



### 3.6 Sound Data

Measurement conditions: Sound pressure level: 1 meter distance between microphone and the air intake.  
 Sound power level: Acc. to DIN 45635 part 38 (ISO 10302)  
 Measured in a semianchoic chamber with a background noise level of  $L_p(A) < 5 \text{ dB(A)}$   
 For further measurement conditions see chapter aerodynamics.

a.) Operation condition:

|                              |             |  |  |
|------------------------------|-------------|--|--|
| 9.700 l/min at free air flow | PWM > 90 %; |  |  |
|------------------------------|-------------|--|--|

|   |                                |  |
|---|--------------------------------|--|
| Optimal operating point   | 44,0 m <sup>3</sup> /h @ 86 Pa |  |
| Sound power level at the optimal operating point                | 6,1 bel(A)                     |  |
| Sound pressure level at free air flow, measured in rubber bands | 48,0 dB(A)                     |  |

## 4 Environment

### 4.1 General

|  |        |  |
|--|--------|--|
| Min. permitted ambient temperature TU min. | -20 °C |  |
| Max. permitted ambient temperature TU max. | 70 °C  |  |
| Min. permitted storage temperature TL min. | -40 °C |  |
| Max. permitted storage temperature TL max. | 80 °C  |  |

### 4.2 Climatic Requirements

|                       |   |  |
|-----------------------|---|--|
| Humidity requirements | humid heat, constant; according to DIN EN 60068-2-78, 14 days |  |
| Water exposure        | None  |  |
| Dust requirements     | None  |  |
| Salt fog requirements | None  |  |

Permitted application area:

The product is intended for use in sheltered rooms with controlled temperature and controlled humidity. Directly exposure to water must be avoided.

Pollution degree 1 (according DIN EN 60664-1)

There is either no pollution or it occurs only dry, non-conductive pollution. The pollution has no negative impact.

Please require severity levels and specification parameters from the responsible development departments.

## 5 Safety

### 5.1 Electrical Safety

|   |  |  |
|---|--|--|
| Dielectric strength<br>DIN EN 60950 (VDE 0805) and DIN EN 60335 (VDE 0700)<br>A.) Type test<br>Measuring conditions: After 48h of storage at 95% R.H. and 25°C.<br>No arcing or breakdown is allowed!<br>All connections together to ground.<br>B.) Routine test<br>Measuring conditions: At indoor climate.<br>No arcing or breakdown is allowed!<br>All connections together to ground. | 500 VAC / 1 Min.<br><br>850 VDC / 1 Sec. |  |
| Isolation resistance<br>Measuring conditions: After 48h of storage at 95% R.H. and 25°C measured with U=500 VDC for 1 min.  | RI > 10 MOhm                             |  |
| Clearance / creepage distance   | 1,0 mm / 1,2 mm                          |  |
| Protection class  | III                                      |  |

### 5.2 Approval Tests

|     |   |   |
|-----|---|---|
| CE  | EC Declaration of Conformity  | Yes   |
| EAC | Eurasian Conformity   | Yes   |
| UL  | Underwriters Laboratories   | Yes / UL507, Electric Fans  |
| VDE | Association for Electrical, Electronic and Information Technologies | Yes / Approval acc. to EN 60950 (VDE 0805) - Information technology equipment |
| CSA | Canadian Standards Association                                      | Yes / C22.2 No. 113 Fans and Ventilators                                      |
| CCC | China Compulsory Certification                                      | Not applicable  |

## 6 Reliability

### 6.1 General

|                                   |          |  |
|-----------------------------------|----------|--|
| Life expectancy L10 at TU = 40 °C | 62.500 h |  |
| Life expectancy L10 at TU max.    | 32.500 h |  |

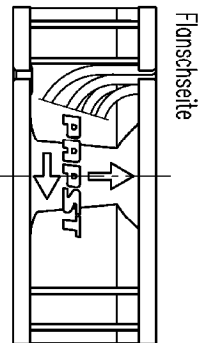
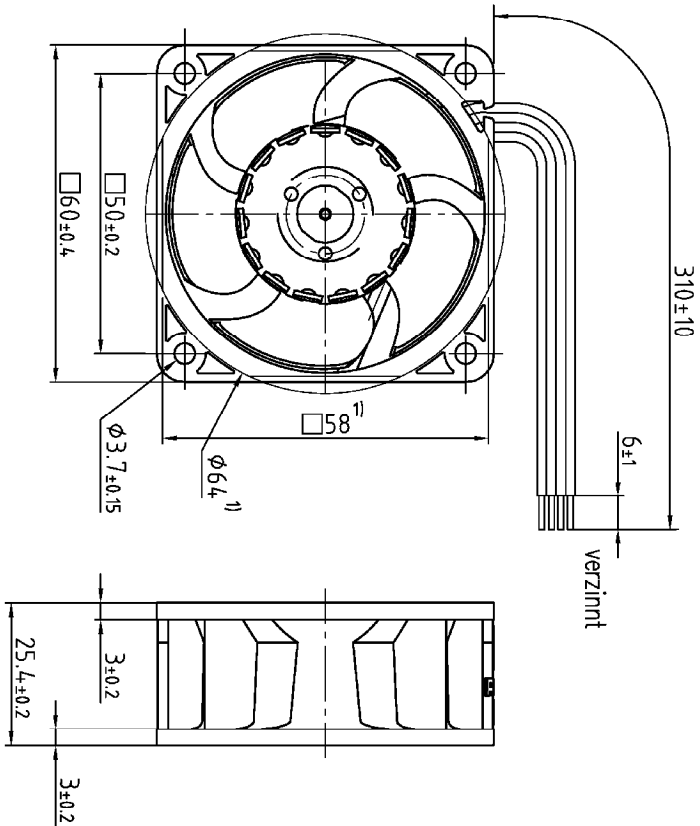

Anzahl und Länge der Litzen s. Stückliste  
 1) Maße für Montagewand  
 Axialspiel bei  
 – Kugellagerung (K) : 0 (mit Federausgleich)  
 – Gleitlagerung (G) :

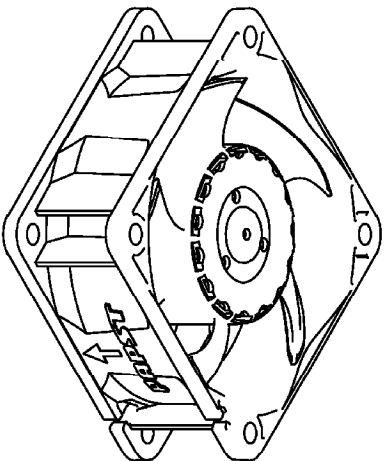

|  |       |                                     |           |             |
|--|-------|-------------------------------------|-----------|-------------|
| Tolerierung: DIN 7167                  |       | Artikel                             |           | Maßstab     |
| Allgemeintoleranzen: DIN ISO 2768-mK-E |       |                                     |           |             |
| Bearbeitet                             | Datum | Name                                |           |             |
|  |       |                                     |           |             |
|  | Index | Aend.-Nr.                           | Zchg.-Nr. | Blatt       |
| Geprüft u. zur Verwendung freigegeben  |       | <b>eimpapst</b>                     |           |             |
| Von                                    | am    | eimpapst Str. Georgen GmbH & Co. KG |           | Ers.f.Zchg. |
|  |       |                                     |           | A4          |