

Product Data Sheet 6312/2TDHP

**ebmpapst**

The engineer's choice



## 6312/2TDHP

## INDEX

<b>1</b>	<b>General</b> .....	<b>3</b>
<b>2</b>	<b>Mechanics</b> .....	<b>3</b>
2.1	General.....	3
2.2	Connections.....	3
<b>3</b>	<b>Operating Data</b> .....	<b>5</b>
3.1	Electrical Interface - Input.....	5
3.2	Electrical Operating Data .....	6
3.3	Electrical Interface - Output.....	7
3.4	Electrical Features.....	8
3.5	Aerodynamics.....	10
3.6	Sound Data.....	11
<b>4</b>	<b>Environment</b> .....	<b>11</b>
4.1	General.....	11
4.2	Climatic Requirements .....	11
<b>5</b>	<b>Safety</b> .....	<b>12</b>
5.1	Electrical Safety.....	12
5.2	Approval Tests .....	12
<b>6</b>	<b>Reliability</b> .....	<b>12</b>
6.1	General.....	12

## 1 General

Fan type	Fan	
Rotating direction looking at rotor	Counterclockwise	
Airflow direction	Air outlet over struts	
Bearing system	Ball bearing	
Mounting position - shaft	Any	

## 2 Mechanics

### 2.1 General

Depth	51,0 mm	
Diameter	172,0 mm	
Mass	0,875 kg	
Housing material	Metal	
Impeller material	Plastic	
Max. torque when mounted across both mounting flanges	Wire outlet corner: 600 Ncm Remaining corners: 600 Ncm	
Screw size	ISO 4762 - M4 degreased, without an additional brace and without washer	

### 2.2 Connections

Electrical connection	Wires	
Lead wire length	L = 365 mm	
Tolerance	+/- 10,0 mm	
Tube length	S = 10 mm	
Tolerance	+/- 2 mm	

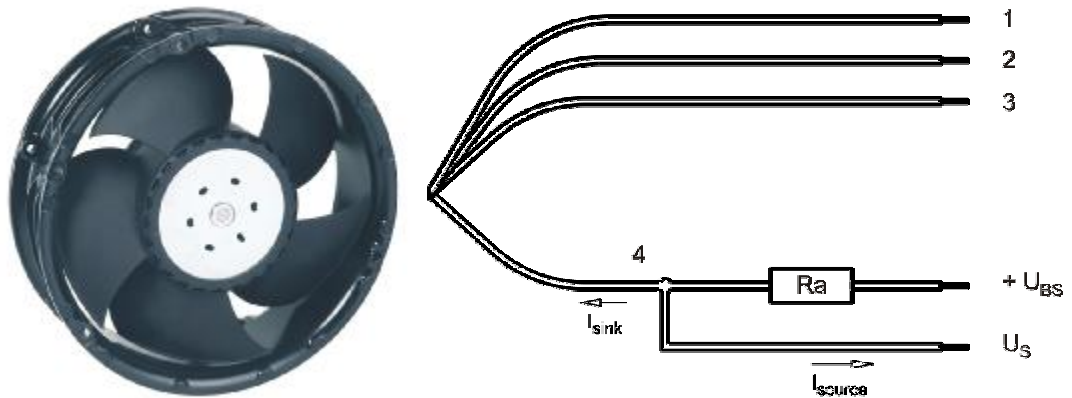

Wire	Color	Operation	Wire size	Insulation diameter
1	red	+ UB	AWG 18	2,05 mm
2	blue	- GND	AWG 18	2,05 mm
3	violet	PWM	AWG 22	1,7 mm
4	white	Tacho	AWG 22	1,7 mm

The auxiliaries shown on the schematic diagram (which are required for the intended use) are not part of our delivery.

Lead wire 1 - 2: AWG18

Lead wire 3 - 4: AWG22 (Insulation diameter 1,7mm)

### 3 Operating Data

#### 3.1 Electrical Interface - Input

Control input	PWM
---------------	-----

#### Features

Input type	Open collector	
PWM - Frequency		1 kHz - 20 kHz typical: 2 kHz

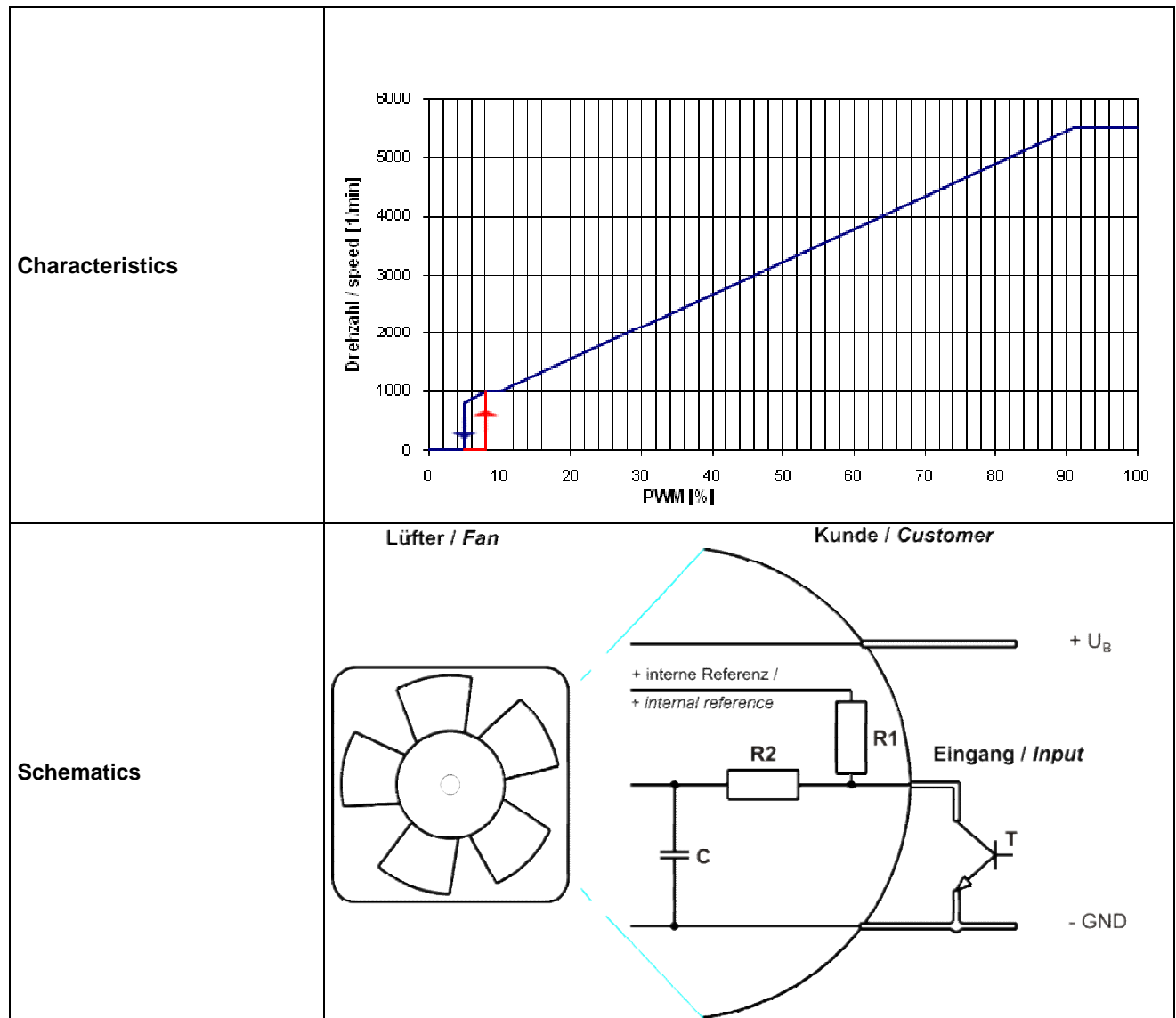

The shown pull-up resistor to the internal reference voltage (+5V) has 4.7kOhm.

**Information to the curve:**

0 % - 7% PWM: 0 1/min  
 7 % PWM: 1.000 1/min (Fan on, coming from 0% PWM)

7 % - 10% PWM: 1.000 1/min (corresponding to min. speed)  
 10 % - 90% PWM: linear increasing curve  
 90 % - 100% PWM: 6.000 1/min (corresponding to max. speed)  
 7 % - 5 % PWM: linear decreasing curve (comming from 100% PWM)  
 5 % PWM: 800 1/min or 0 1/min (Fan off, comming from 100% PWM)

**Transistor Requirements:**

VCE max.  $\geq$  12V  
 Isink max  $>$  5mA  
 VCEsat  $<$  0,15V

**3.2 Electrical Operating Data**

Measurement conditions: Normal air density = 1,2 kg/m<sup>3</sup>; Temperature 23°C +/- 3°C; Motor axis horizontal; warm-up time before measuring 5 minutes (unless otherwise specified). In the intake and outlet area should not be any solid obstruction within 0,5 m.

$\Delta p = 0$ : corresp. to free air flow (see chapter aerodynamics)  
 I: corresp. to arithm. mean current value

Name	Condition
PWM 0001	PWM: 95 %; f: 2 kHz

>90% PWM; f = 2 kHz or broken lead wire (open control input)

Features	Condition	Symbol	Values		
Voltage range		U	8 V		16,0 V
Nominal voltage		U <sub>N</sub>		12,0 V	
Power consumption	$\Delta p = 0$	P	33 W	41 W	44,0 W
Tolerance	PWM 0010		+/- 12,5 %	+/- 10,0 %	+/- 10,0 %
Current consumption	$\Delta p = 0$	I	4.100 mA	3.400 mA	2.750 mA
Tolerance	PWM 0010		+/- 12,5 %	+/- 10,0 %	+/- 10,0 %
Speed	$\Delta p = 0$	n	5.100 1/min	5.500 1/min	5.500 1/min
Tolerance	PWM 0010		+/- 7,5 %	+/- 5,0 %	+/- 5,0 %

3.3 Electrical Interface - Output

Tacho type	/2 (open collector)
------------	---------------------

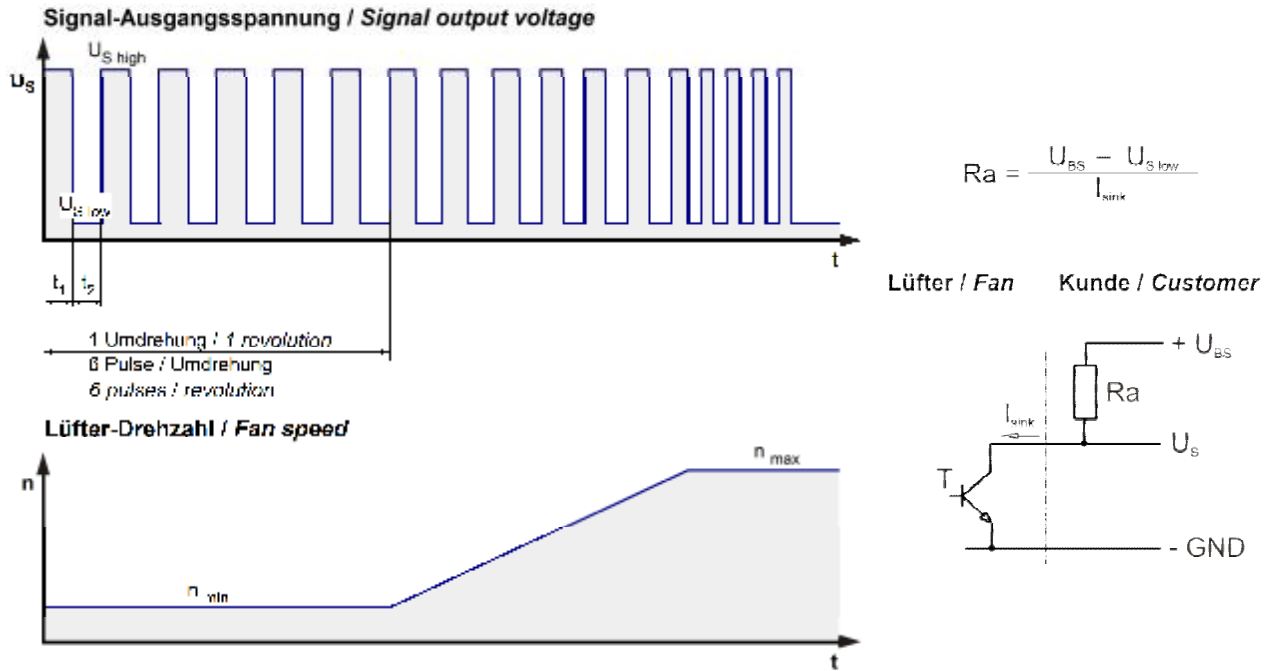

Features	Note	Values
Tacho operating voltage	$U_{BS}$	$\leq 60,0\ V$
Tacho signal Low	$U_{S\ low}$	$I_{sink}: 2\ mA$ $\leq 0,4\ V$
Tacho signal High	$U_{S\ high}$	$I_{source}: 0\ mA$ $60,0\ V$
Maximum sink current	$I_{sink}$	$\leq 20\ mA$
External resistor	External resistor $R_a$ from $U_{BS}$ to $U_S$ required. All voltages measured to GND.	
Tacho frequency	$(6 \times n) / 60$	
Tacho isolated from motor	No	
Slew rate		$\Rightarrow 0,5\ V/\mu s$

$n$  = revolutions per minute (1/min)

**Please note:**

At zero speed the tacho signal is at a static HIGH. It will be also HIGH when the fan is still spinning, but the speed control signal is set to zero speed already. The tacho signal is only activated after the start-up is completed.

### 3.4 Electrical Features

Electronic function	Speed-Controlled	
Reversed polarity protection	P-CH FET	
Max. residual current at $U_N$	$I_F \leq 5 \text{ mA}$	
Locked rotor protection	Auto restart	
Locked rotor current at $U_N$	$I_{\text{block}}$ approx. 5.000 mA	
Clock signal at locked rotor	$t_3 / t_4$ typical: 6,0 s / 10,0 s	

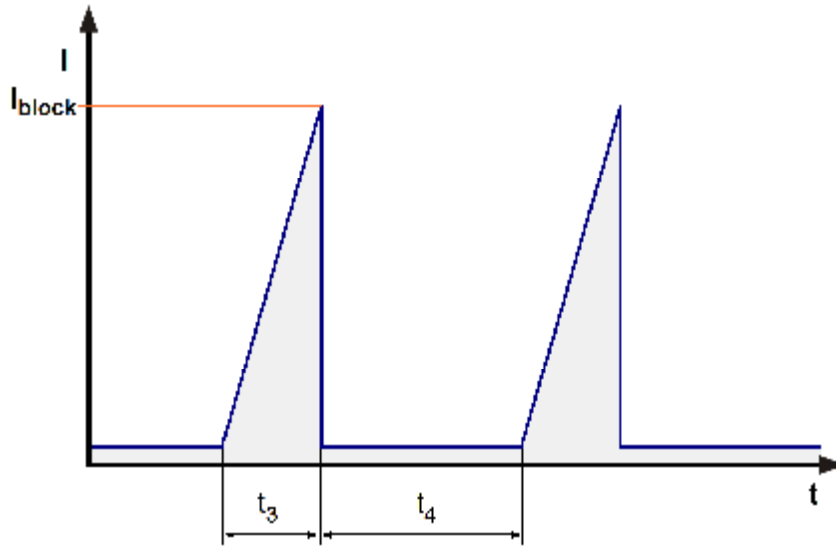

This fan has a startup delay of 2 seconds after applying supply voltage.

Each startup ( $t_3$ ) has two steps. Positioning of the rotor (ca. 3-4s) and the actual startup (~3s).

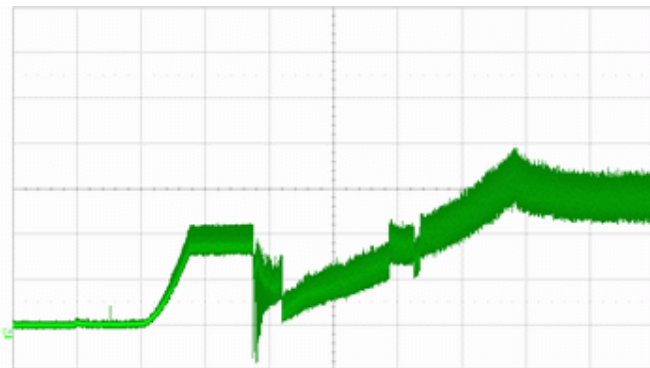

Start-up current @ 12 V ( $I = 1\text{A/div}$  ;  $t = 2\text{s/div}$ )



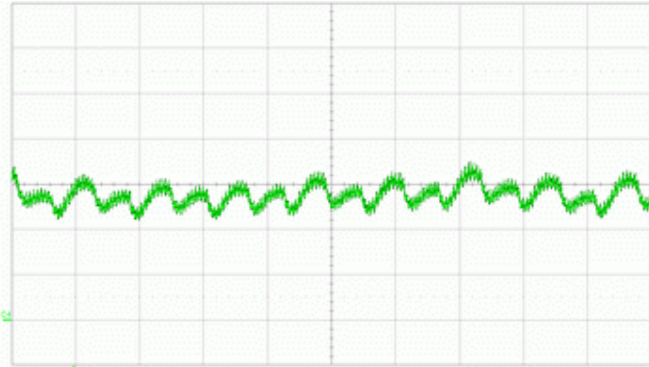

Running current @ 12 V (I = 1A/div ; t = 500ms/div)

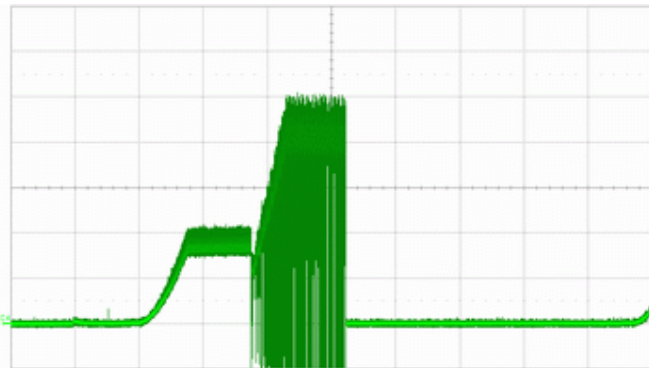

Locked rotor current @ 12 V (I = 1A/div ; t = 2s/div)

**Internal Fuse:**

Littelfuse Nano2 Fuse  
Very Fast-Acting 451/453 Series  
15A / 125V

### 3.5 Aerodynamics

Measurement conditions: Measured with a double chamber intake rig acc. to DIN EN ISO 5801.  
 Normal air density = 1,2 kg/m<sup>3</sup>; Temperature 23°C +/- 3°C;  
 In the intake and outlet area should not be any solid obstruction within 0,5 m. Motor shaft horizontal.  
 The information is only valid under the specified test conditions and may be changed by the installation conditions. If there are deviations from the standard test conditions, the characteristic values must be checked under the installed conditions.

a.) Operation condition:

5.500 1/min at free air flow	PWM 95 %; f: 2 kHz		
------------------------------	--------------------	--	--

Max. free-air flow ( $\Delta p = 0 / \dot{V} = \text{max.}$ )	590,0 m <sup>3</sup> /h	
Max. static pressure ( $\Delta p = \text{max.} / \dot{V} = 0$ )	560 Pa	

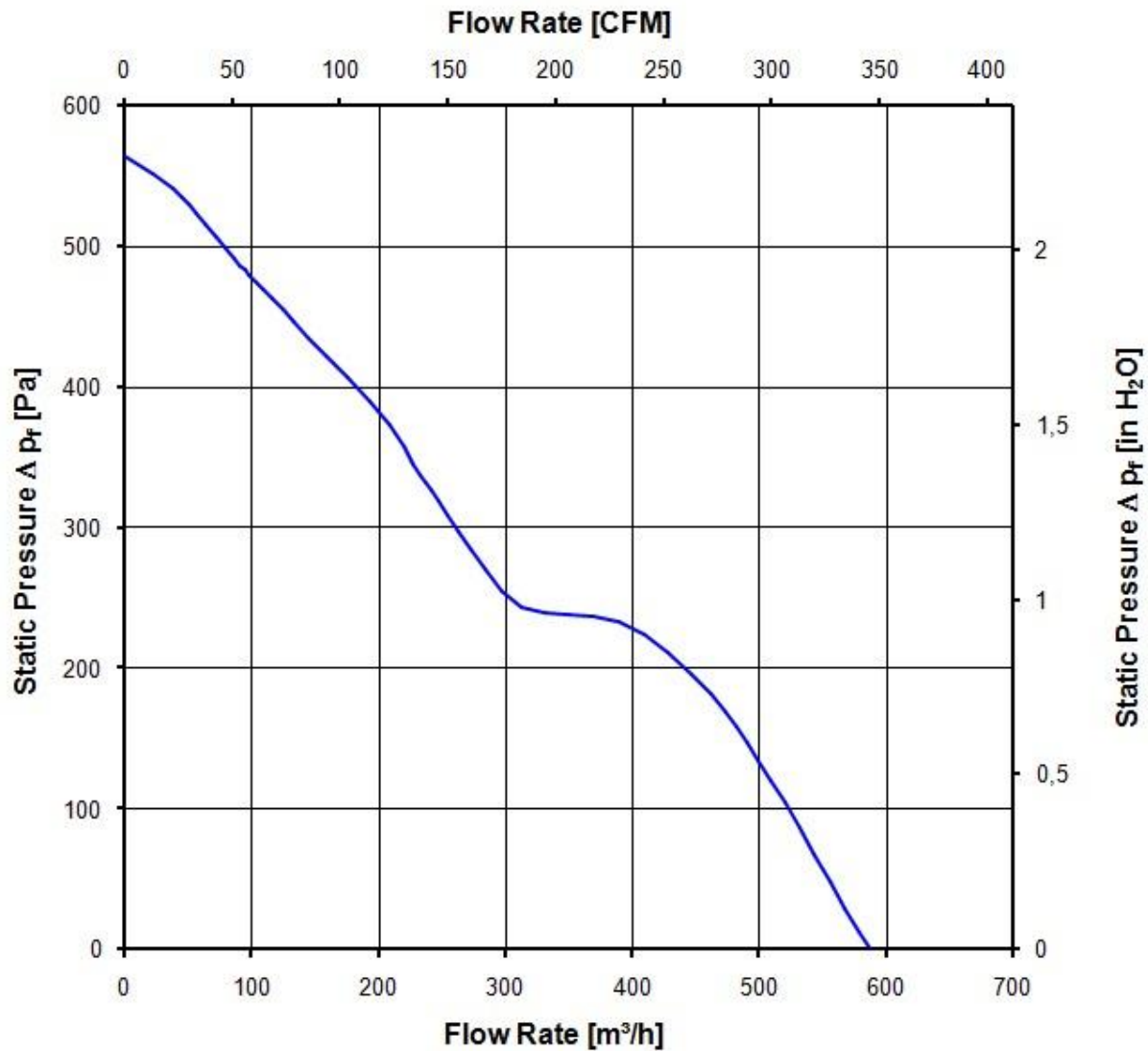

### 3.6 Sound Data

Measurement conditions: Sound pressure level: 1 meter distance between microphone and the air intake.  
 Sound power level: Acc. to DIN 45635 part 38 (ISO 10302)  
 Measured in a semianchoic chamber with a background noise level of  $L_p(A) < 5 \text{ dB(A)}$   
 For further measurement conditions see chapter aerodynamics.

a.) Operation condition:

5.500 1/min at free air flow	PWM 95 %; f: 2 kHz		
Optimal operating point	565,0 m <sup>3</sup> /h @ 28 Pa		
Sound power level at the optimal operating point	7,6 bel(A)		
Sound pressure level at free air flow, measured in rubber bands	64,0 dB(A)		

## 4 Environment

### 4.1 General

Min. permitted ambient temperature TU min.	-20 °C	
Max. permitted ambient temperature TU max.	70 °C	
Min. permitted storage temperature TL min.	-40 °C	
Max. permitted storage temperature TL max.	80 °C	

### 4.2 Climatic Requirements

Humidity requirements	humid heat, constant; according to DIN EN 60068-2-78, 14 days	
Water exposure	None	
Dust requirements	None	
Salt fog requirements	None	

Permitted application area:

The product is intended for use in sheltered rooms with controlled temperature and controlled humidity. Directly exposure to water must be avoided.

Pollution degree 1 (according DIN EN 60664-1)

There is either no pollution or it occurs only dry, non-conductive pollution. The pollution has no negative impact.

Please require severity levels and specification parameters from the responsible development departments.

## 5 Safety

### 5.1 Electrical Safety

Dielectric strength DIN EN 60950 (VDE 0805) and DIN EN 60335 (VDE 0700) A.) Type test Measuring conditions: After 48h of storage at 95% R.H. and 25°C. No arcing or breakdown is allowed! All connections together to ground. B.) Routine test Measuring conditions: At indoor climate. No arcing or breakdown is allowed! All connections together to ground.	500 VAC / 1 Min.  850 VDC / 1 Sec.	
Isolation resistance Measuring conditions: After 48h of storage at 95% R.H. and 25°C measured with U=500 VDC for 1 min.	RI > 10 MOhm	
Clearance / creepage distance	1,0 mm / 1,2 mm	
Protection class	III	

### 5.2 Approval Tests

CE	EC Declaration of Conformity	No
EAC	Eurasian Conformity	Yes
UL	Underwriters Laboratories	Yes / UL audited by CSA according to UL507, Electric Fans
VDE	Association for Electrical, Electronic and Information Technologies	Yes / Approval acc. to EN 60950 (VDE 0805) - Information technology equipment
CSA	Canadian Standards Association	Yes / C22.2 No. 113 Fans and Ventilators
CCC	China Compulsory Certification	Not applicable

The approval tests are observed to:

U approval max.:16,0 V @ TU approval max.: 70,0 °C

## 6 Reliability

### 6.1 General

Life expectancy L10 at TU = 40 °C	70.000 h	
Life expectancy L10 at TU max.	35.000 h	
Life expectancy L10 acc. to IPC 9591 at TU = 40 °C	117.500 h	

1) Maß für Montageausschnitt  
 2) Anzahl und Länge der Litzen und des Schlauches siehe Produktspezifikation

1) measures of mounting cut out  
 2) length an number of wires and tube see product specification

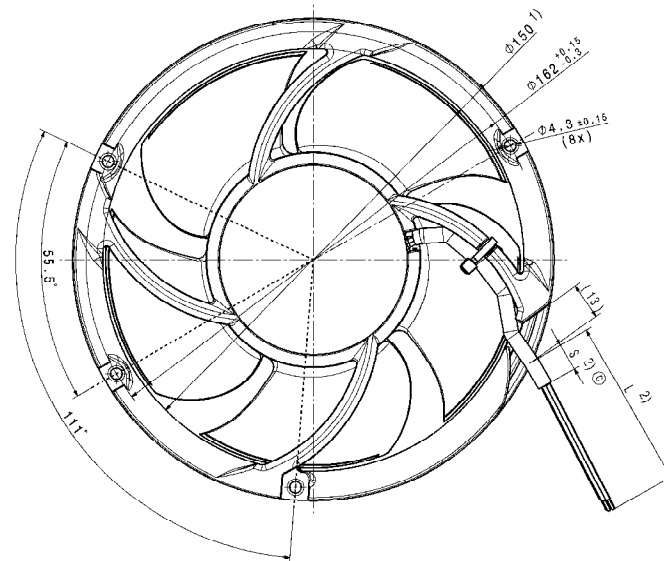
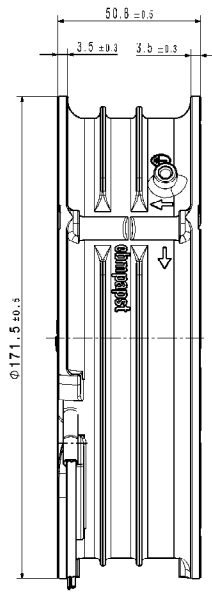
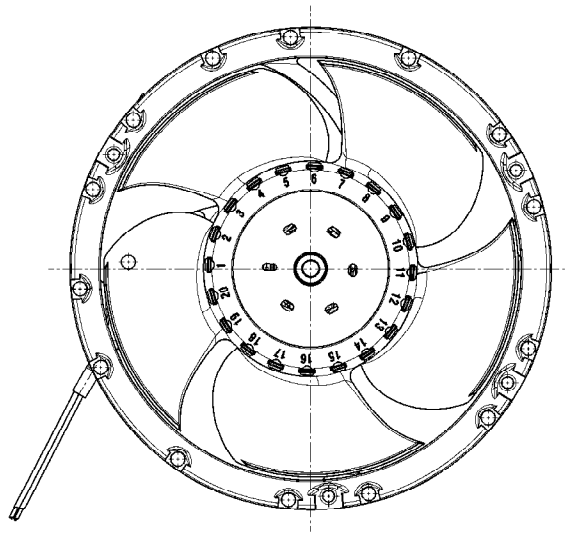

- Axialspiel der Kugellager mit Feder spielfrei gelagert  
 1) Maße für Montageausschnitt  
 2) Anzahl und Länge der Litzen und des Schlauches siehe Produktspezifikation

- ball bearing without clearance by a pre-load spring  
 1) measures of mounting cut out  
 2) length an number of wires and tube see product specification

BE-Zeichnung 	Part. No.: Zeich. No.:	2D-Zeichnung 2D-Zeichnung	3D-Modell 3D-Modell	Material / Material: Material / Material:	Menge / Menge: Menge / Menge:
		Name: Name:	Name: Name:	Name / Teil: Name / Teil:	Name / Teil: Name / Teil:
Beschreibung / Address: Beschreibung / Address:	Art / Version: Art / Version:	Datum: Datum:	Status: Status:	Dring. Nr. / Drawing No.: Dring. Nr. / Drawing No.:	Frz. / Qty. / Copies: Frz. / Qty. / Copies:
Abgleichdimensionen / See tolerances: Abgleichdimensionen / See tolerances:	<b>ebmpapst</b> <small>www.ebmpapst.com</small>		Erzeuger / Manufacturer: Erzeuger / Manufacturer:	Zeich. / Drawing: Zeich. / Drawing:	Blatt / Sheet: Blatt / Sheet: