

Product Data Sheet 6424 M

**ebmpapst**

The engineer's choice



6424 M

## INDEX

<b>1</b>	<b>General</b> .....	<b>3</b>
<b>2</b>	<b>Mechanics</b> .....	<b>3</b>
2.1	General.....	3
2.2	Connections.....	3
<b>3</b>	<b>Operating Data</b> .....	<b>4</b>
3.1	Electrical Operating Data .....	4
3.2	Electrical Features.....	4
3.3	Aerodynamics.....	6
3.4	Sound Data.....	7
<b>4</b>	<b>Environment</b> .....	<b>7</b>
4.1	General.....	7
4.2	Climatic Requirements .....	7
<b>5</b>	<b>Safety</b> .....	<b>8</b>
5.1	Electrical Safety.....	8
5.2	Approval Tests .....	8
<b>6</b>	<b>Reliability</b> .....	<b>8</b>
6.1	General.....	8

**1 General**

Fan type	Fan	
Rotating direction looking at rotor	Counterclockwise	
Airflow direction	Air outlet over struts	
Bearing system	Ball bearing	
Mounting position - shaft	Any	

**2 Mechanics****2.1 General**

Width	150,0 mm	
Depth	51,0 mm	
Diameter	172,0 mm	
Mass	0,760 kg	
Housing material	Metal	
Impeller material	Plastic	
Max. torque when mounted across both mounting flanges	Wire outlet corner: 260 Ncm Remaining corners: 260 Ncm	
Screw size	ISO 4762 - M4 degreased, without an additional brace and without washer	

**2.2 Connections**

Electrical connection	Plug	
Lead wire length	See drawing	
Tolerance		
Plug	See drawing	
Contact	See drawing	



⎓	- GND
⎓	+ UB

### 3 Operating Data

#### 3.1 Electrical Operating Data

Measurement conditions: Normal air density = 1,2 kg/m<sup>3</sup>; Temperature 23°C +/- 3°C; Motor axis horizontal; warm-up time before measuring 5 minutes (unless otherwise specified). In the intake and outlet area should not be any solid obstruction within 0,5 m.

$\Delta p = 0$ : corresp. to free air flow (see chapter aerodynamics)  
I: corresp. to arithm. mean current value

Note:

No inrush current at  $U_{nom}$  means:

The internal electrolytic capacitor 120uF/50V has no resistor or inrush current limitation, essentially the power supply and the type and length of the connecting cable is limiting the Inrush current.

Features	Condition	Symbol	Values		
Voltage range		U	12,0 V		32,0 V
Nominal voltage		$U_N$		24 V	
Power consumption	$\Delta p = 0$	P	1,9 W	12,0 W	20,5 W
Tolerance	0010		+/- 20 %	+/- 20 %	+/- 20 %
Current consumption	$\Delta p = 0$	I	160 mA	500 mA	670 mA
Tolerance	0010		+/- 20 %	+/- 20 %	+/- 20 %
Speed	$\Delta p = 0$	n	1.400 1/min	2.850 1/min	3.800 1/min
Tolerance	0010		+/- 10 %	+/- 12,5 %	+/- 10 %
Starting current consumption				2.100 mA	

#### 3.2 Electrical Features

Electronic function	None	
Reversed polarity protection	Rectifying diode	
Max. residual current at $U_N$	$I_F < 10$ mA	
Locked rotor protection	Auto restart	
Locked rotor current at $U_N$	$I_{block}$ approx. 2.100 mA	
Clock signal at locked rotor	$t_3 / t_4$ typical: 1,4 s / 5,3 s	



### 3.3 Aerodynamics

Measurement conditions: Measured with a double chamber intake rig acc. to DIN EN ISO 5801.  
 Normal air density = 1,2 kg/m<sup>3</sup>; Temperature 23°C +/- 3°C;  
 In the intake and outlet area should not be any solid obstruction within 0,5 m. Motor shaft horizontal.  
 The information is only valid under the specified test conditions and may be changed by the installation conditions. If there are deviations from the standard test conditions, the characteristic values must be checked under the installed conditions.

a.) Operation condition:

2.850 1/min at free air flow		
Max. free-air flow ( $\Delta p = 0 / \dot{V} = \text{max.}$ )	325,0 m <sup>3</sup> /h	
Max. static pressure ( $\Delta p = \text{max.} / \dot{V} = 0$ )	136 Pa	

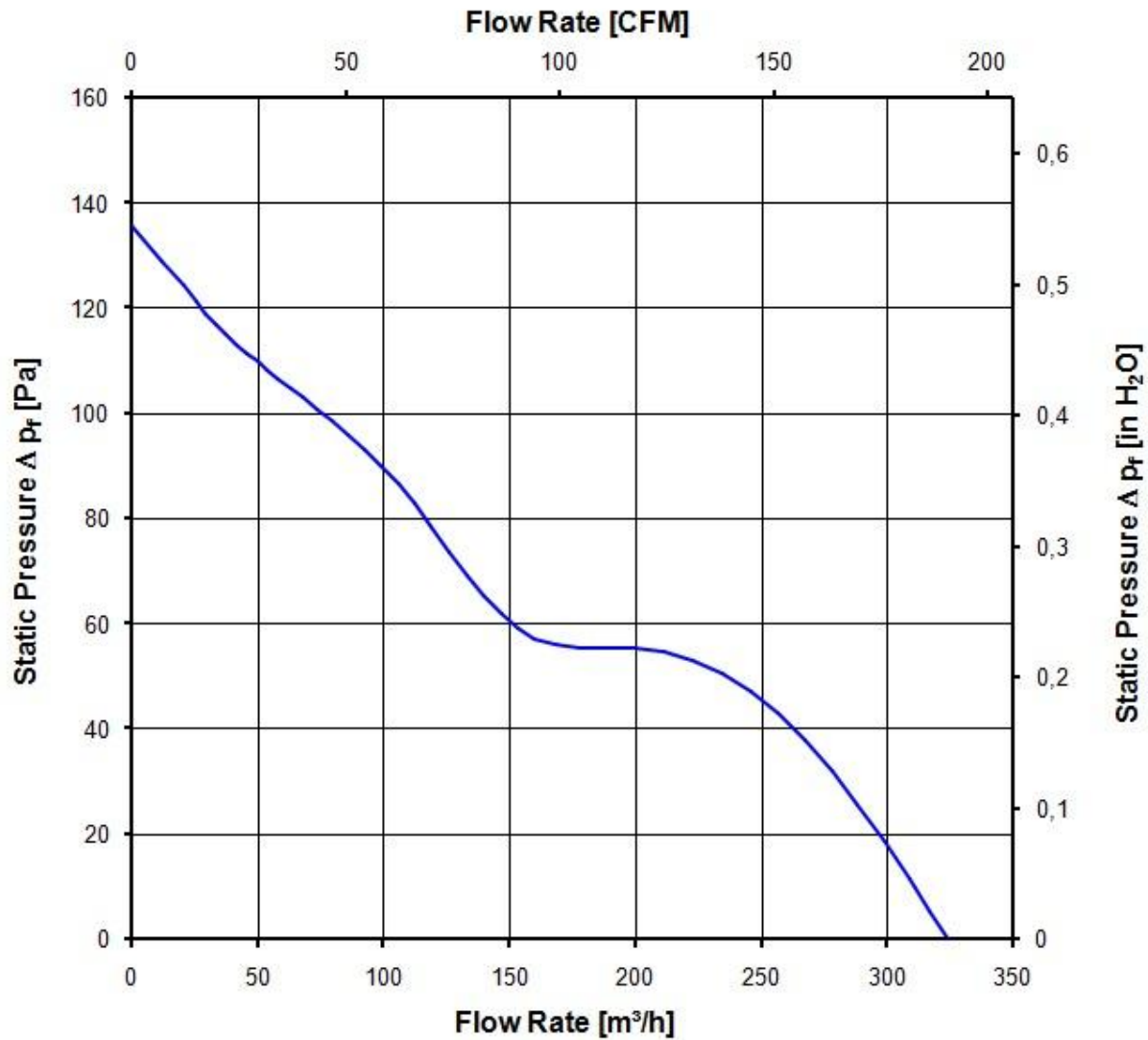

### 3.4 Sound Data

Measurement conditions: Sound pressure level: 1 meter distance between microphone and the air intake.  
 Sound power level: Acc. to DIN 45635 part 38 (ISO 10302)  
 Measured in a semianchoic chamber with a background noise level of  $L_p(A) < 5 \text{ dB(A)}$   
 For further measurement conditions see chapter aerodynamics.

a.) Operation condition:

2.850 1/min at free air flow
------------------------------

Optimal operating point	225,0 m <sup>3</sup> /h @ 47 Pa	
Sound power level at the optimal operating point	6,1 bel(A)	
Sound pressure level at free air flow, measured in rubber bands	49,0 dB(A)	

## 4 Environment

### 4.1 General

Min. permitted ambient temperature TU min.	-20 °C	
Max. permitted ambient temperature TU max.	72 °C	
Min. permitted storage temperature TL min.	-40 °C	
Max. permitted storage temperature TL max.	80 °C	

### 4.2 Climatic Requirements

Humidity requirements	humid heat, constant; according to DIN EN 60068-2-78, 14 days	
Water exposure	None	
Dust requirements	None	
Salt fog requirements	None	

Permitted application area:

The product is intended for use in sheltered rooms with controlled temperature and controlled humidity. Directly exposure to water must be avoided.

Pollution degree 1 (according DIN EN 60664-1)

There is either no pollution or it occurs only dry, non-conductive pollution. The pollution has no negative impact.

Please require severity levels and specification parameters from the responsible development departments.

## 5 Safety

### 5.1 Electrical Safety

Dielectric strength DIN EN 60950 (VDE 0805) and DIN EN 60335 (VDE 0700) A.) Type test Measuring conditions: After 48h of storage at 95% R.H. and 25°C. No arcing or breakdown is allowed! All connections together to ground. B.) Routine test Measuring conditions: At indoor climate. No arcing or breakdown is allowed! All connections together to ground.	500 VAC / 1 Min.  850 VDC / 1 Sec.	
Isolation resistance Measuring conditions: After 48h of storage at 95% R.H. and 25°C measured with U=500 VDC for 1 min.	RI > 10 MOhm	
Clearance / creepage distance	1,0 mm / 1,2 mm	
Protection class	III	

### 5.2 Approval Tests

CE	EC Declaration of Conformity	Yes
EAC	Eurasian Conformity	Yes
UL	Underwriters Laboratories	Yes / UL507, Electric Fans
VDE	Association for Electrical, Electronic and Information Technologies	Yes / Approval acc. to EN 60950 (VDE 0805) - Information technology equipment
CSA	Canadian Standards Association	Yes / C22.2 No. 113 Fans and Ventilators
CCC	China Compulsory Certification	Not applicable

## 6 Reliability

### 6.1 General

Life expectancy L10 at TU = 40 °C	80.000 h	
Life expectancy L10 at TU max.	37.500 h	
Life expectancy L10 acc. to IPC 9591 at TU = 40 °C	135.000 h	



Copyright of the drawings and files: In these and all other documents of the company, there are  
 included with the necessary security. Offences shall be by a court of law. All rights are reserved  
 in the event of the grant of a patent or the registration of a utility model or design.

Schutzvermerk nach DIN ISO 6484 beachten!  
 Refer to protection notice DIN ISO 6484!

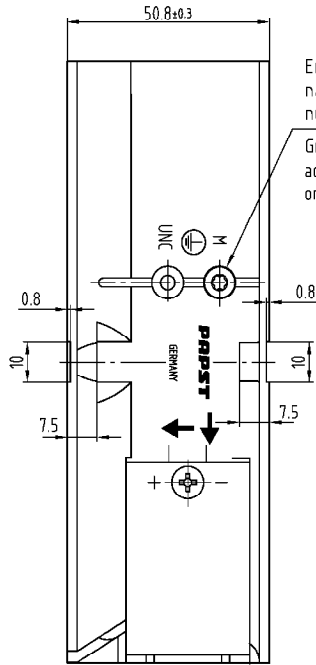

①  
 Erdungsschraube Duo-TapTite  
 nach DIN 7500, CM 4x8, Torx  
 nur, wenn in Unterstückliste enthalten.

Grounding screw Duo-TapTite  
 according to DIN 7500, CM 4x8, Torx  
 only, if contained in sub-bill of material.

Maße für Steckeranschluss  
 dimensions for plug connector

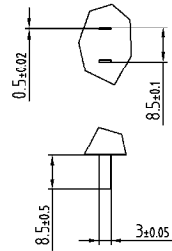

- Axialspiel: mit Feder spielfrei verspannt

1) Maße für Montagewand

2) nur, wenn in Stückliste enthalten

- without axial clearance by a pre-loaded spring

1) dimensions for assembly wall

2) only, if contained in bill of material

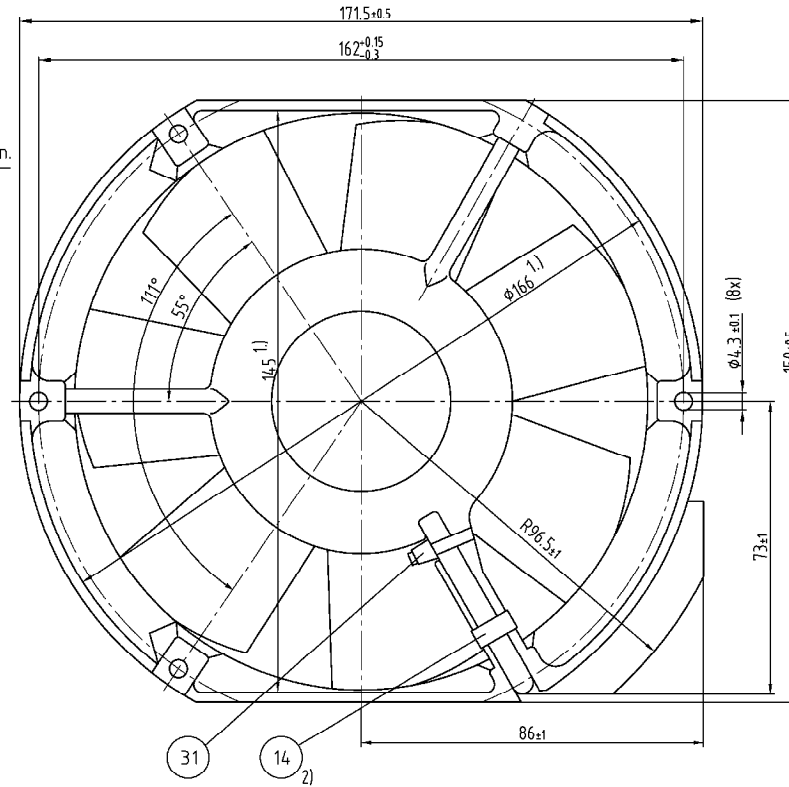

SAP-Status/State	Änd. Nr./Change No.	AP/CAO-System-Version	ebmpapst		Werkstoff/Material:	Volumen/Volume (mm³):		
			CAD-Umgebung/ CAD-Environment				Gewicht/Mass (g):	
		Datum/Date	Name/Name	Artikel/TITLE				
				Zeich.-Nr./Drawing-No.:	Ers./Zchg./Replaces:			
Tolerierung/Tolerances:								
Allgemeintoleranzen/Gen. tolerances:				ebmpapst St. Leonen GmbH & Co. KG				
				Dokumenl./Type of Document	Zeichenuml./Bull/Pagel	Index/Box	Format/Size	Missst./d/Scale