

Product Data Sheet 8218 J/2H4P

**ebmpapst**

The engineer's choice



8218 J/2H4P

INDEX

**1 General ..... 3**

**2 Mechanics ..... 3**

    2.1 General ..... 3

    2.2 Connections ..... 3

**3 Operating Data ..... 4**

    3.1 Electrical Interface - Input ..... 4

    3.2 Electrical Operating Data ..... 5

    3.3 Electrical Interface - Output ..... 6

    3.4 Electrical Features ..... 7

    3.5 Aerodynamics ..... 8

    3.6 Sound Data ..... 9

**4 Environment ..... 9**

    4.1 General ..... 9

    4.2 Climatic Requirements ..... 9

**5 Safety ..... 10**

    5.1 Electrical Safety ..... 10

    5.2 Approval Tests ..... 10

**6 Reliability ..... 10**

    6.1 General ..... 10

## 1 General

Fan type	Fan	
Rotating direction looking at rotor	Counterclockwise	
Airflow direction	Air outlet over struts	
Bearing system	Ball bearing	
Mounting position - shaft	Any	

## 2 Mechanics

### 2.1 General

Width	80,0 mm	
Height	80,0 mm	
Depth	38,0 mm	
Mass	0,210 kg	
Housing material	Plastic	
Impeller material	Plastic	
Max. torque when mounted across both mounting flanges	Wire outlet corner: 50 Ncm Remaining corners: 110 Ncm	
Screw size	ISO 4762 - M4 degreased, without an additional brace and without washer	

### 2.2 Connections

Electrical connection	Wires	
Lead wire length	L = 310 mm	
Tolerance	+/- 10,0 mm	
Wire size (AWG)	22	
Insulation diameter	1,30 mm	

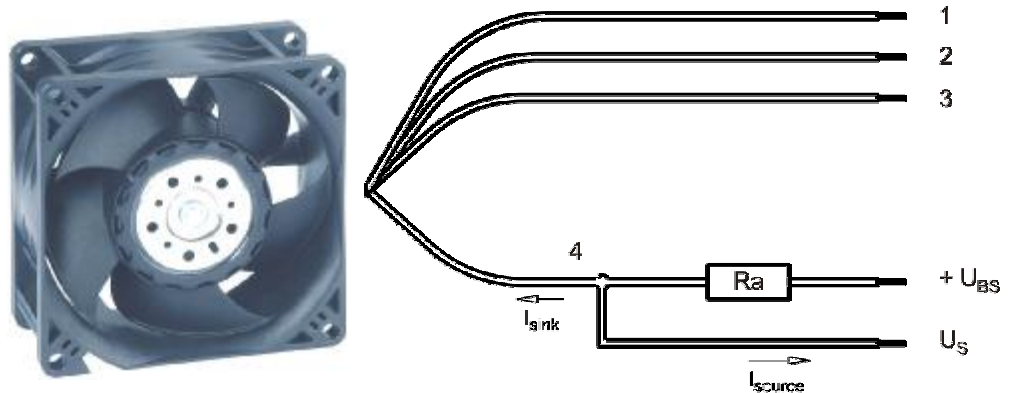

Wire	Color	Operation
1	red	+ UB
2	blue	- GND
3	violet	PWM
4	white	Tacho

The auxiliaries shown on the schematic diagram (which are required for the intended use) are not part of our delivery.

### 3 Operating Data

#### 3.1 Electrical Interface - Input

Control input	PWM
---------------	-----

#### Features

Input type	Open collector	
PWM - Frequency		1 kHz - 5 kHz

<b>Characteristics</b>	<table border="1" style="margin: 10px auto;"> <caption>Speed vs PWM Data</caption> <thead> <tr> <th>PWM [%]</th> <th>Speed [1/min]</th> </tr> </thead> <tbody> <tr><td>0</td><td>0</td></tr> <tr><td>10</td><td>2000</td></tr> <tr><td>20</td><td>4000</td></tr> <tr><td>30</td><td>6000</td></tr> <tr><td>40</td><td>8000</td></tr> <tr><td>50</td><td>10000</td></tr> <tr><td>60</td><td>12000</td></tr> <tr><td>70</td><td>14000</td></tr> <tr><td>80</td><td>16000</td></tr> <tr><td>90</td><td>18000</td></tr> <tr><td>100</td><td>18000</td></tr> </tbody> </table>	PWM [%]	Speed [1/min]	0	0	10	2000	20	4000	30	6000	40	8000	50	10000	60	12000	70	14000	80	16000	90	18000	100	18000
PWM [%]	Speed [1/min]																								
0	0																								
10	2000																								
20	4000																								
30	6000																								
40	8000																								
50	10000																								
60	12000																								
70	14000																								
80	16000																								
90	18000																								
100	18000																								
<b>Schematics</b>																									

PWM 0... 100 %, PWM-Low < 0,2 V

### 3.2 Electrical Operating Data

Measurement conditions: Normal air density = 1,2 kg/m<sup>3</sup>; Temperature 23°C +/- 3°C; Motor axis horizontal; warm-up time before measuring 5 minutes (unless otherwise specified). In the intake and outlet area should not be any solid obstruction within 0,5 m.

$\Delta p = 0$ : corresp. to free air flow (see chapter aerodynamics)  
 I: corresp. to arithm. mean current value

Name	Condition		
PWM 0001	PWM: 100 %;	f: 1 kHz	f: 5 kHz

Features	Condition	Symbol	Values		
Voltage range		U	20 V		58,0 V
Nominal voltage		$U_N$		48,0 V	
Power consumption	$\Delta p = 0$	P	6 W	37 W	37,0 W
Tolerance	PWM 0010		+/- 17,5 %	+/- 17,5 %	+/- 25,0 %
Current consumption	$\Delta p = 0$	I	300 mA	770 mA	650 mA
Tolerance	PWM 0010		+/- 17,5 %	+/- 17,5 %	+/- 25,0 %
Speed	$\Delta p = 0$	n	7.300 1/min	14.000 1/min	14.000 1/min
Tolerance	PWM 0010		+/- 12,5 %	+/- 7,5 %	+/- 3,0 %
Starting current consumption				2.800 mA	

3.3 Electrical Interface - Output

Tacho type	/2 (open collector)
------------	---------------------

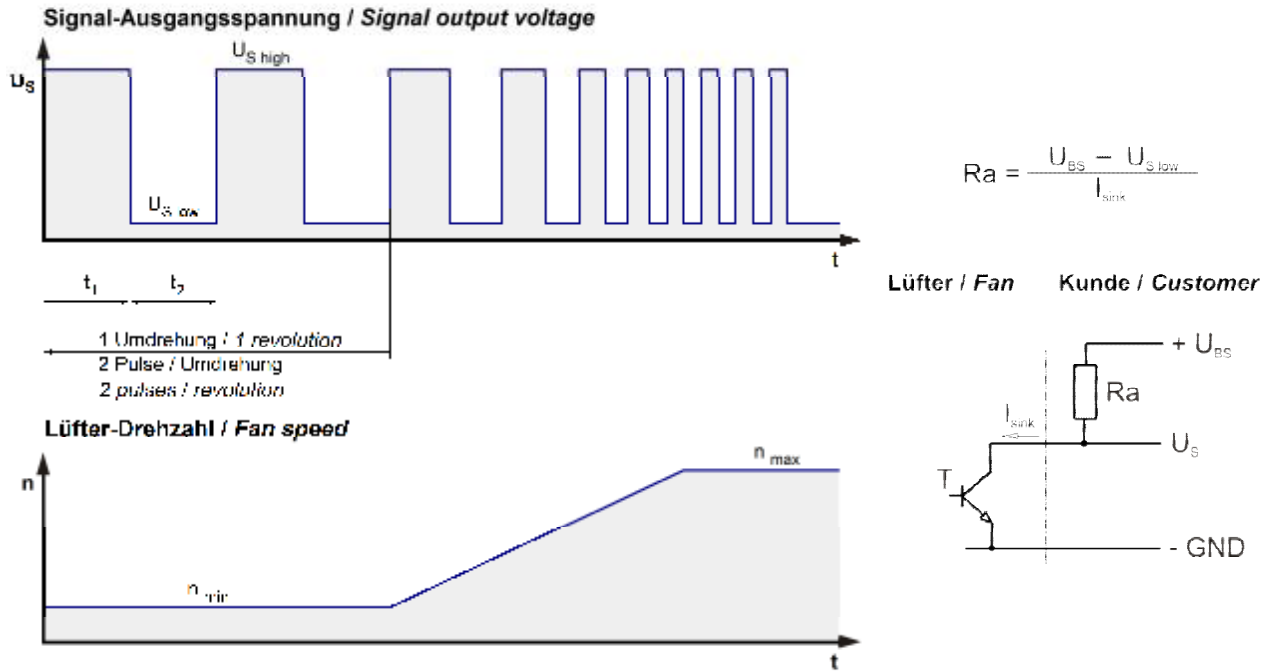

Features	Note	Values
Tacho operating voltage	$U_{BS}$	$\leq 60,0$ V
Tacho signal Low	$U_{S,low}$	$I_{sink}: 2$ mA $\leq 0,4$ V
Tacho signal High	$U_{S,high}$	$I_{source}: 0$ mA $\leq 60,0$ V
Maximum sink current	$I_{sink}$	$\leq 4$ mA
External resistor	External resistor $R_a$ from $U_{BS}$ to $U_S$ required. All voltages measured to GND.	
Tacho frequency	$(2 \times n) / 60$	
Tacho isolated from motor	No	
Slew rate		$\Rightarrow 0,5$ V/us

$n$  = revolutions per minute (1/min)

### 3.4 Electrical Features

Electronic function	Speed-Controlled	
Reversed polarity protection	Rectifying diode	
Max. residual current at $U_N$	$I_F \leq 100 \mu\text{A}$	
Locked rotor protection	Auto restart	
Locked rotor current at $U_N$	$I_{\text{block}}$ approx. 2.800 mA	
Clock signal at locked rotor	$t_3 / t_4$ typical: 0,5 s / 10,0 s	

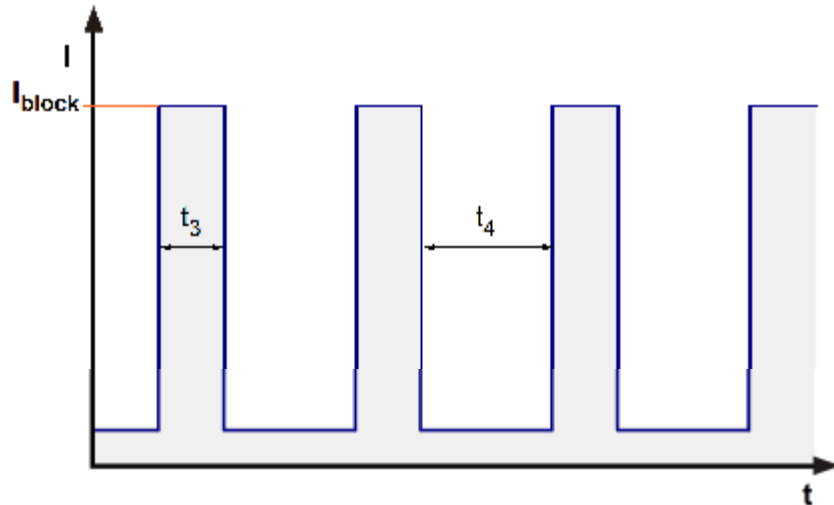

### 3.5 Aerodynamics

Measurement conditions: Measured with a double chamber intake rig acc. to DIN EN ISO 5801.  
 Normal air density = 1,2 kg/m<sup>3</sup>; Temperature 23°C +/- 3°C;  
 In the intake and outlet area should not be any solid obstruction within 0,5 m. Motor shaft horizontal.  
 The information is only valid under the specified test conditions and may be changed by the installation conditions. If there are deviations from the standard test conditions, the characteristic values must be checked under the installed conditions.

a.) Operation condition:

14.000 1/min at free air flow	PWM 100 %;	f: 1 kHz	f: 5 kHz
-------------------------------	------------	----------	----------

Max. free-air flow ( $\Delta p = 0 / \dot{V} = \text{max.}$ )	220,0 m <sup>3</sup> /h
Max. static pressure ( $\Delta p = \text{max.} / \dot{V} = 0$ )	710 Pa

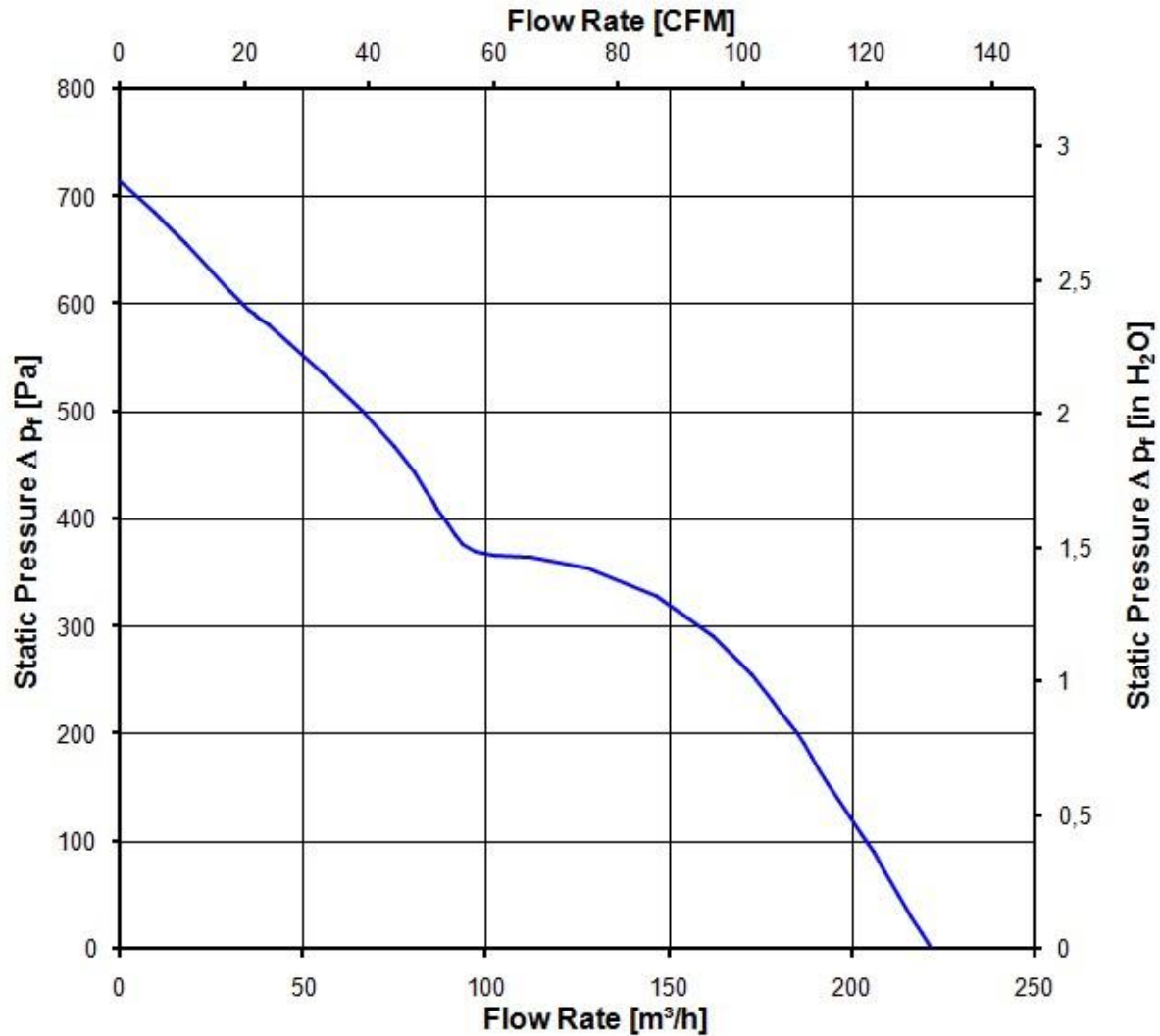



### 3.6 Sound Data

Measurement conditions: Sound pressure level: 1 meter distance between microphone and the air intake.  
 Sound power level: Acc. to DIN 45635 part 38 (ISO 10302)  
 Measured in a semianchoic chamber with a background noise level of  $L_p(A) < 5 \text{ dB(A)}$   
 For further measurement conditions see chapter aerodynamics.

a.) Operation condition:

14.000 1/min at free air flow	PWM 100 %;	f: 1 kHz	f: 5 kHz
-------------------------------	------------	----------	----------

Optimal operating point	135,0 m <sup>3</sup> /h @ 330 Pa	
Sound power level at the optimal operating point	8,0 bel(A)	
Sound pressure level at free air flow, measured in rubber bands	71,0 dB(A)	

## 4 Environment

### 4.1 General

Min. permitted ambient temperature TU min.	-20 °C	
Max. permitted ambient temperature TU max.	70 °C	
Min. permitted storage temperature TL min.	-40 °C	
Max. permitted storage temperature TL max.	80 °C	

### 4.2 Climatic Requirements

Humidity requirements	humid heat, constant; according to DIN EN 60068-2-78, 14 days	
Water exposure	None	
Dust requirements	None	
Salt fog requirements	None	

Permitted application area:

The product is intended for use in sheltered rooms with controlled temperature and controlled humidity. Directly exposure to water must be avoided.

Pollution degree 1 (according DIN EN 60664-1)

There is either no pollution or it occurs only dry, non-conductive pollution. The pollution has no negative impact.

Please require severity levels and specification parameters from the responsible development departments.

## 5 Safety

### 5.1 Electrical Safety

Dielectric strength DIN EN 60950 (VDE 0805) and DIN EN 60335 (VDE 0700) A.) Type test Measuring conditions: After 48h of storage at 95% R.H. and 25°C. No arcing or breakdown is allowed! All connections together to ground. B.) Routine test Measuring conditions: At indoor climate. No arcing or breakdown is allowed! All connections together to ground.	500 VAC / 1 Min.  850 VDC / 1 Sec.	
Isolation resistance Measuring conditions: After 48h of storage at 95% R.H. and 25°C measured with U=500 VDC for 1 min.	RI > 10 MOhm	
Clearance / creepage distance	1,0 mm / 1,5 mm	
Protection class	III	

### 5.2 Approval Tests

CE	EC Declaration of Conformity	Yes
EAC	Eurasian Conformity	Yes
UL	Underwriters Laboratories	Yes / UL507, Electric Fans
VDE	Association for Electrical, Electronic and Information Technologies	Yes / Approval acc. to EN 60950 (VDE 0805) - Information technology equipment
CSA	Canadian Standards Association	Yes / C22.2 No. 113 Fans and Ventilators
CCC	China Compulsory Certification	Yes / GB 12350 Safety Requirements for small Power Motors

The approval tests are observed to:

U approval max.: 52,8 V @ TU approval max.: 70,0 °C

## 6 Reliability

### 6.1 General

Life expectancy L10 at TU = 40 °C	50.000 h	
Life expectancy L10 at TU max.	25.000 h	
Life expectancy L10 acc. to IPC 9591 at TU = 40 °C	85.000 h	

Nothing of this document, nor doing, is allowed to be used for administration of the current thereof, are  
 forbidden without express authority. Offenders are liable to the payment of damages. All rights are reserved  
 in the event of the patent or a patent or the registration of a utility model or design.

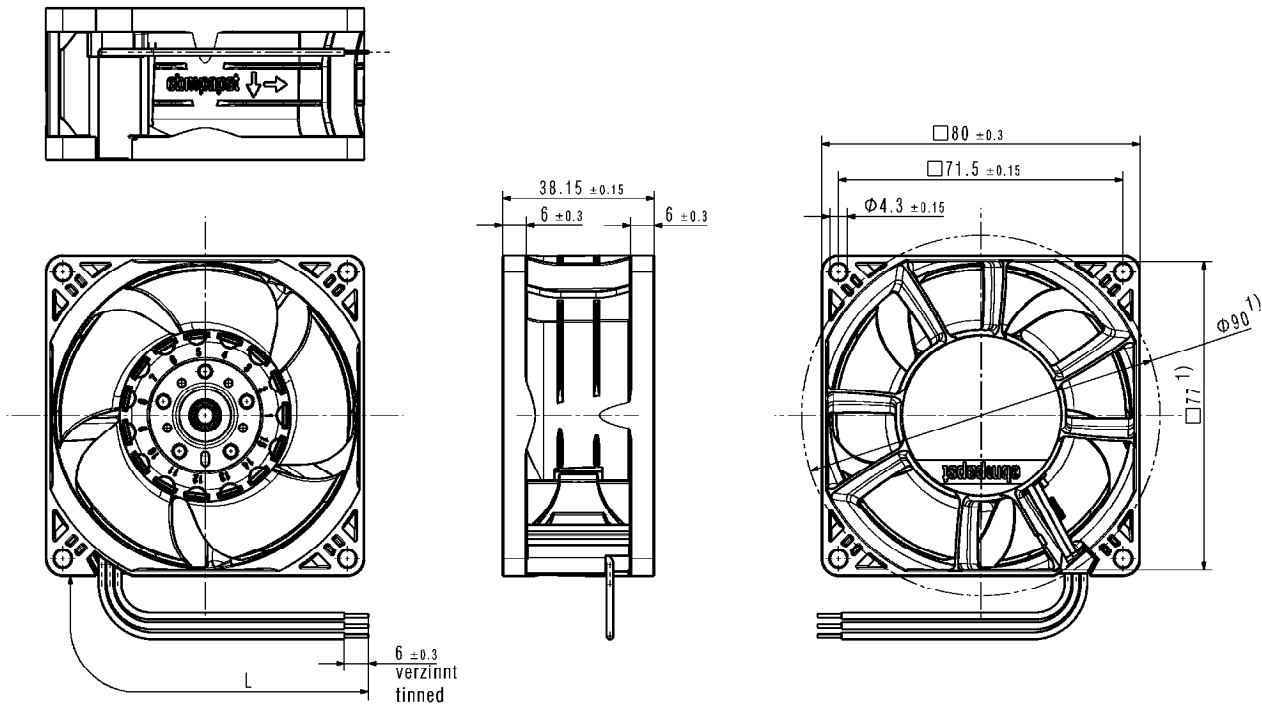

Subcontractors need this file for 3D CAD models /  
 Refer to production notes for 3D CAD files



1) Maße für Montagewand  
 1) dimension for worktop mounting

Laenge und Anzahl der Litzen siehe Produktspezifikation  
 length and number of the wires, look at the produkt specification

Kein Axialspiel bei Kugellager durch Federausgleich  
 no axial clearance of ball bearings conditional on a pre-load spring

Datum / State / Document State CATEA-Version / CATEA-Version		CAD-Umgebung / CAD-Environment		Material / Material:		Volumen / Volume (cm³):	
 3D-Referenzmodell / 3D-Referenzmodell: 06091003 CAD1000		Artikel / Title:		Gewicht / Mass (kg):			
Tolerierung / Tolerances:		Datum / Name:		Zeich.-Nr. / Drawing No:		Ersatzteile / Replaces:	
Allgemeine Toleranzen / Gen. Tolerances:		Reviz. / Rev. / Change:		Index / Index:		Format / Size:	
		Dokument / Type of Document		Zeichnung / (Sheet/Page)		Maßstab / Scale:	
ebm-papst St. Georgen GmbH & Co. KG							