

Product Data Sheet 8412 N/2GHP

**ebmpapst**

The engineer's choice



**8412 N/2GHP****INDEX**

<b>1</b>	<b>General</b> .....	<b>3</b>
<b>2</b>	<b>Mechanics</b> .....	<b>3</b>
2.1	General.....	3
2.2	Connections.....	3
<b>3</b>	<b>Operating Data</b> .....	<b>4</b>
3.1	Electrical Interface - Input.....	4
3.2	Electrical Operating Data .....	5
3.3	Electrical Interface - Output.....	6
3.4	Electrical Features.....	7
3.5	Aerodynamics.....	8
3.6	Sound Data.....	9
<b>4</b>	<b>Environment</b> .....	<b>9</b>
4.1	General.....	9
4.2	Climatic Requirements .....	9
4.3	EMC.....	9
<b>5</b>	<b>Safety</b> .....	<b>11</b>
5.1	Electrical Safety.....	11
5.2	Approval Tests .....	11
<b>6</b>	<b>Reliability</b> .....	<b>11</b>
6.1	General.....	11

## 1 General

Fan type	Fan	
Rotating direction looking at rotor	Counterclockwise	
Airflow direction	Air outlet over struts	
Bearing system	Sleeve bearing	
Mounting position - shaft	Any	

## 2 Mechanics

### 2.1 General

Width	80,0 mm	
Height	80,0 mm	
Depth	25,4 mm	
Mass	0,095 kg	
Housing material	Plastic	
Impeller material	Plastic	
Max. torque when mounted across both mounting flanges	Wire outlet corner: 50 Ncm Remaining corners: 70 Ncm	
Screw size	ISO 4762 - M4 degreased, without an additional brace and without washer	

### 2.2 Connections

Electrical connection	Wires	
Lead wire length	L = 310 mm	
Tolerance	+/- 10,0 mm	
Wire size (AWG)	26	
Insulation diameter	1,35 mm	

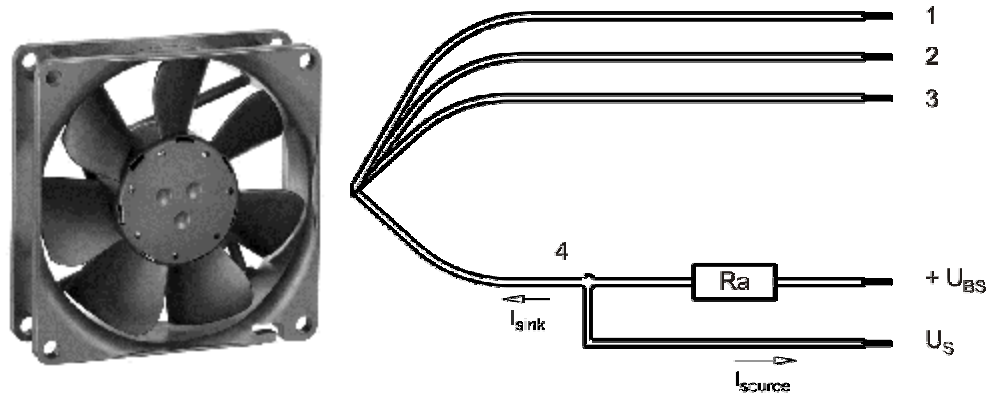

Wire	Color	Operation
1	red	+ UB
2	blue	- GND
3	violet	PWM
4	white	Tacho

The auxiliaries shown on the schematic diagram (which are required for the intended use) are not part of our delivery.

### 3 Operating Data

#### 3.1 Electrical Interface - Input

Control input	PWM
---------------	-----

#### Features

Input type	Open collector / TTL	
PWM - Frequency		21 kHz - 28 kHz typical: 25 kHz
Max. voltage for logic "Low"		0,8 V
Max. voltage for logic "High"	Open circuit voltage	5,25 V
Maximum source current	short circuit current	$\leq 5$ mA
4 wire startup condition	PWM duty cycle	$> 25$ %
4 wire operation condition after startup	PWM duty cycle	20 % - 100 %
Shutdown condition	PWM duty cycle	$< 1$ %
Typical time until warm restart	After shutdown by PWM	$\sim 1,2$ s

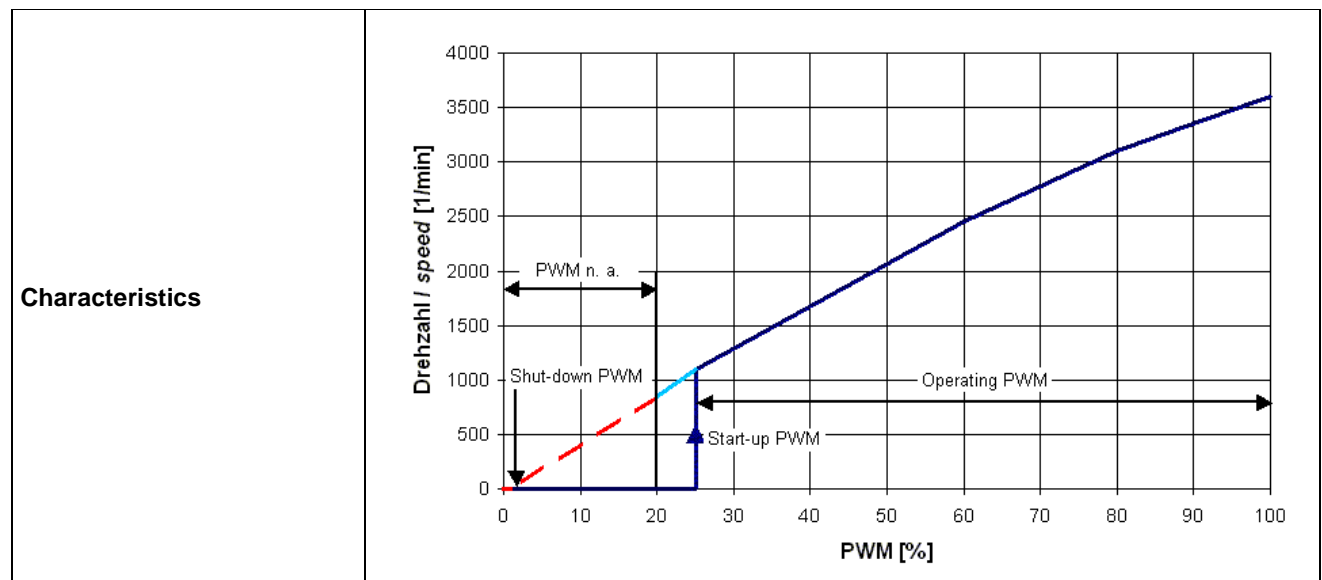

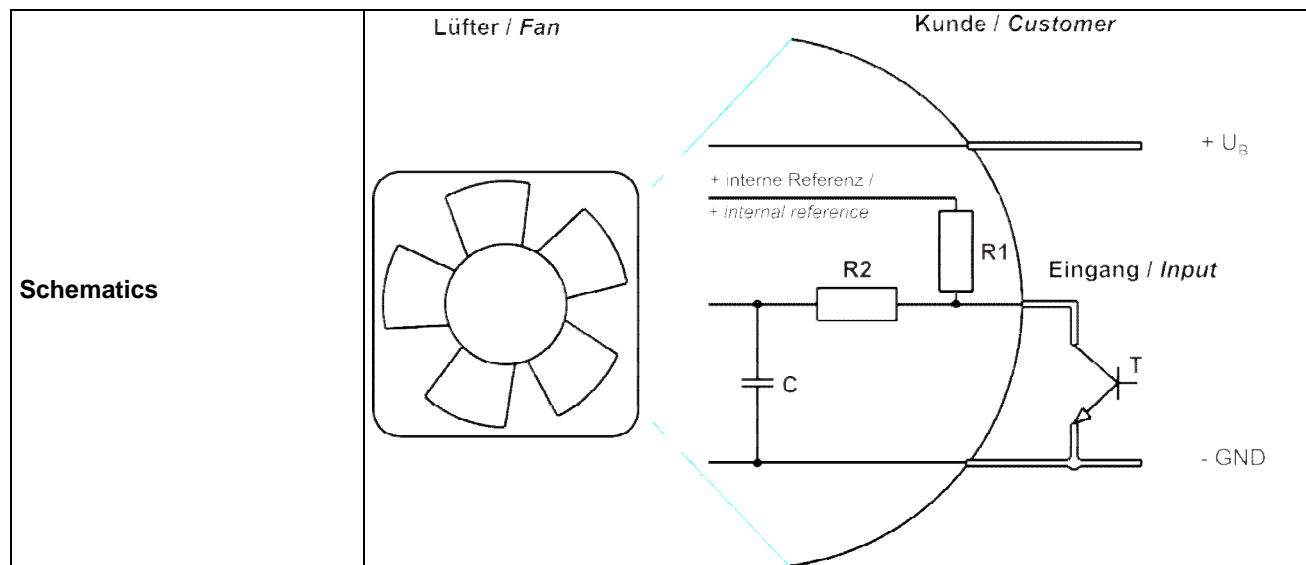

### 3.2 Electrical Operating Data

Measurement conditions: Normal air density = 1,2 kg/m<sup>3</sup>; Temperature 23°C +/- 3°C; Motor axis horizontal; warm-up time before measuring 5 minutes (unless otherwise specified). In the intake and outlet area should not be any solid obstruction within 0,5 m.

$\Delta p = 0$ : corresp. to free air flow (see chapter aerodynamics)  
 I: corresp. to arithm. mean current value

Name	Condition
PWM 0001	PWM: 100 %; f: 25 kHz

Features	Condition	Symbol	Values		
Voltage range		U	10,8 V		13,2 V
Nominal voltage		$U_N$		12 V	
Power consumption	$\Delta p = 0$	P	2,4 W	3 W	3,7 W
Tolerance	PWM 0010		+/- 17,5 %	+/- 12,5 %	+/- 15 %
Current consumption	$\Delta p = 0$	I	220 mA	250 mA	280 mA
Tolerance	PWM 0010		+/- 17,5 %	+/- 12,5 %	+/- 15 %
Speed	$\Delta p = 0$	n	3.350 1/min	3.600 1/min	3.900 1/min
Tolerance	PWM 0010		+/- 12,5 %	+/- 7,5 %	+/- 10 %
Starting current consumption				335 mA	

3.3 Electrical Interface - Output

Tacho type	/2 (open collector)
------------	---------------------

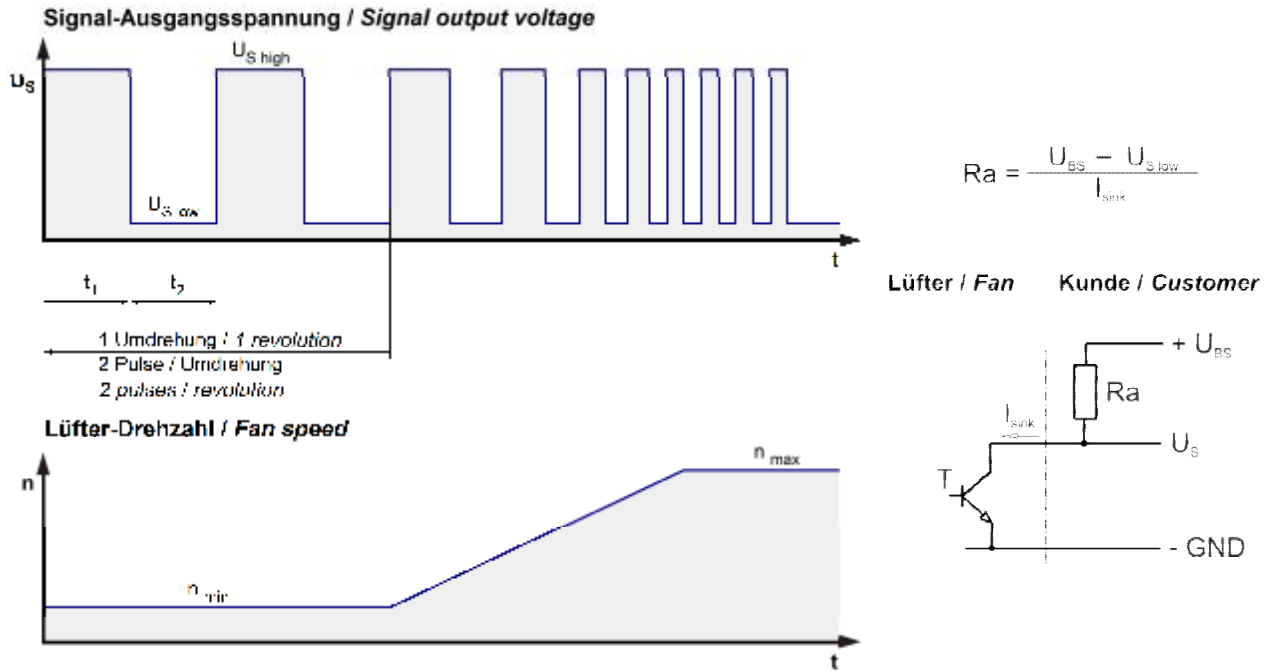

Features	Note	Values
Tacho operating voltage	$U_{BS}$	$\leq 28$ V
Tacho signal Low	$U_{S,low}$	$I_{sink}: 2$ mA $\leq 0,4$ V
Tacho signal High	$U_{S,high}$	$I_{source}: 0$ mA 28 V
Maximum sink current	$I_{sink}$	$\leq 4$ mA
External resistor	External resistor $R_a$ from $U_{BS}$ to $U_S$ required. All voltages measured to GND.	
Tacho frequency	$(2 \times n) / 60$	120 Hz
Tacho isolated from motor	No	
Slew rate		$\Rightarrow 0,5$ V/us

$n$  = revolutions per minute (1/min)

### 3.4 Electrical Features

Electronic function	Speed-Controlled	
Reversed polarity protection	Rectifying diode	
Max. residual current at $U_N$	$I_F \leq 8 \text{ mA}$	
Locked rotor protection	Auto restart	
Locked rotor current at $U_N$	$I_{\text{block}}$ approx. 335 mA	
Clock signal at locked rotor	$t_3 / t_4$ typical: 0,27 s / 1,2 s	

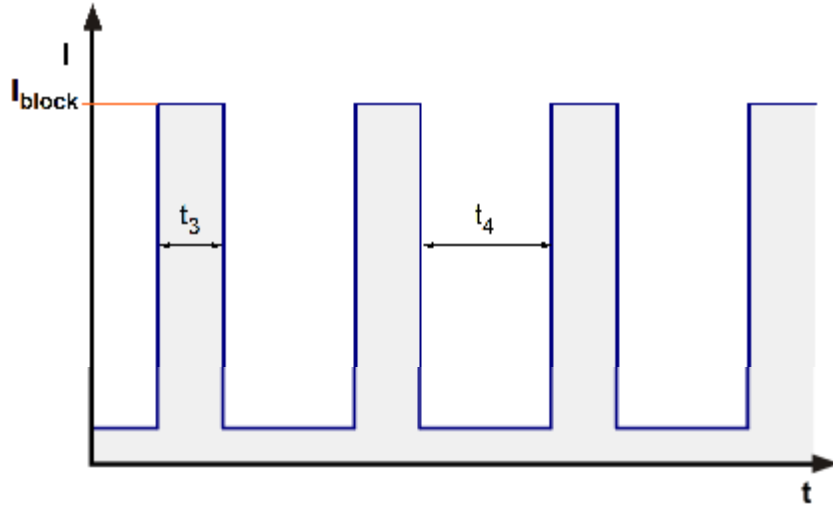

### 3.5 Aerodynamics

Measurement conditions: Measured with a double chamber intake rig acc. to DIN EN ISO 5801.  
 Normal air density = 1,2 kg/m<sup>3</sup>; Temperature 23°C +/- 3°C;  
 In the intake and outlet area should not be any solid obstruction within 0,5 m. Motor shaft horizontal.  
 The information is only valid under the specified test conditions and may be changed by the installation conditions. If there are deviations from the standard test conditions, the characteristic values must be checked under the installed conditions.

a.) Operation condition:

3.600 1/min at free air flow	PWM 100 %; f: 25 kHz		
------------------------------	----------------------	--	--

Max. free-air flow ( $\Delta p = 0 / \dot{V} = \text{max.}$ )	78,0 m <sup>3</sup> /h	
Max. static pressure ( $\Delta p = \text{max.} / \dot{V} = 0$ )	58 Pa	

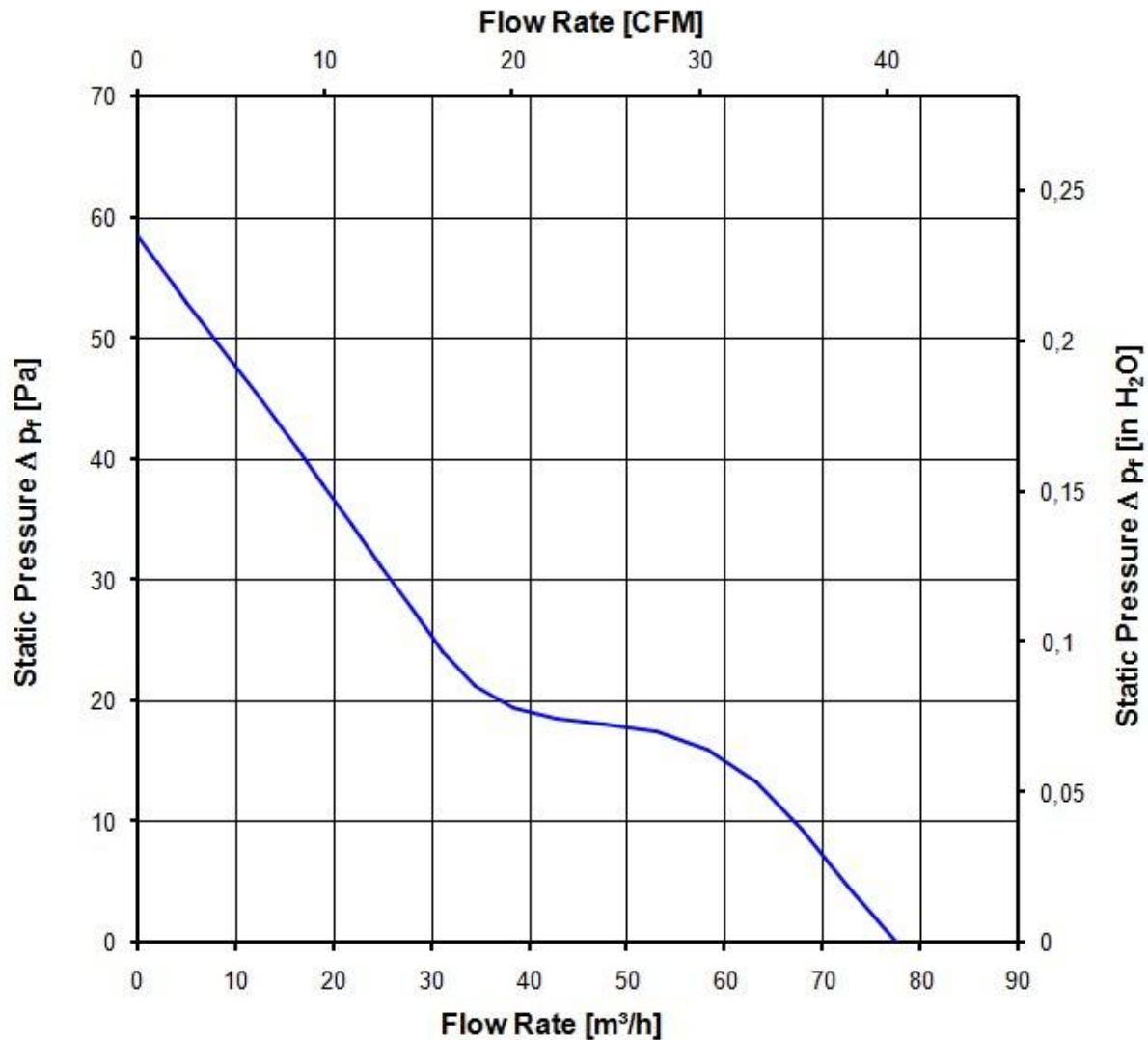



### 3.6 Sound Data

Measurement conditions: Sound pressure level: 1 meter distance between microphone and the air intake.  
 Sound power level: Acc. to DIN 45635 part 38 (ISO 10302)  
 Measured in a semianchoic chamber with a background noise level of  $L_p(A) < 5 \text{ dB(A)}$   
 For further measurement conditions see chapter aerodynamics.

a.) Operation condition:

3.600 1/min at free air flow	PWM 100 %; f: 25 kHz		
Optimal operating point	64,0 m <sup>3</sup> /h @ 14 Pa		
Sound power level at the optimal operating point	5,0 bel(A)		
Sound pressure level at free air flow, measured in rubber bands	37,0 dB(A)		

## 4 Environment

### 4.1 General

Min. permitted ambient temperature TU min.	0 °C	
Max. permitted ambient temperature TU max.	70 °C	
Min. permitted storage temperature TL min.	-40 °C	
Max. permitted storage temperature TL max.	80 °C	

### 4.2 Climatic Requirements

Humidity requirements	humid heat, constant; according to DIN EN 60068-2-78, 14 days	
Water exposure	None	
Dust requirements	None	
Salt fog requirements	None	

Permitted application area:

The product is intended for use in sheltered rooms with controlled temperature and controlled humidity. Directly exposure to water must be avoided.

Pollution degree 1 (according DIN EN 60664-1)

There is either no pollution or it occurs only dry, non-conductive pollution. The pollution has no negative impact.

Please require severity levels and specification parameters from the responsible development departments.

### 4.3 EMC

<b>Kind</b>	<b>Radiated Emission; 30 MHz - 1000 MHz</b>
According	DIN EN 55022:2007-04
Check accuracy / Limit	Class B
Result	Below limit Class B

<b>Kind</b>	<b>Electrostatic Discharge Immunity Test</b>
According	DIN EN 61000-4-2:2001-12
Check accuracy / Limit	Contact Discharge +/- 4 kV; Air Discharge +/- 8 kV
Result	A: The monitored function operates as designed during and after exposure to a disturbance.

**5 Safety**

**5.1 Electrical Safety**

Dielectric strength DIN EN 60950 (VDE 0805) and DIN EN 60335 (VDE 0700) A.) Type test Measuring conditions: After 48h of storage at 95% R.H. and 25°C. No arcing or breakdown is allowed! All connections together to ground.	Not applicable	
B.) Routine test Measuring conditions: At indoor climate. No arcing or breakdown is allowed! All connections together to ground.	Not applicable	
Isolation resistance Measuring conditions: After 48h of storage at 95% R.H. and 25°C measured with U=500 VDC for 1 min.	RI > 10 MOhm	
Clearance / creepage distance	1,0 mm / 1,2 mm	
Protection class	III	

**5.2 Approval Tests**

CE	EC Declaration of Conformity	Yes
EAC	Eurasian Conformity	Yes
UL	Underwriters Laboratories	Yes / UL507, Electric Fans
VDE	Association for Electrical, Electronic and Information Technologies	Yes / Approval acc. to EN 60950 (VDE 0805) - Information technology equipment
CSA	Canadian Standards Association	Yes
CCC	China Compulsory Certification	Not applicable

**6 Reliability**

**6.1 General**

Life expectancy L10 at TU = 40 °C	70.000 h	
Life expectancy L10 at TU max.	35.000 h	
Life expectancy L10 acc. to IPC 9591 at TU = 40 °C	117.500 h	

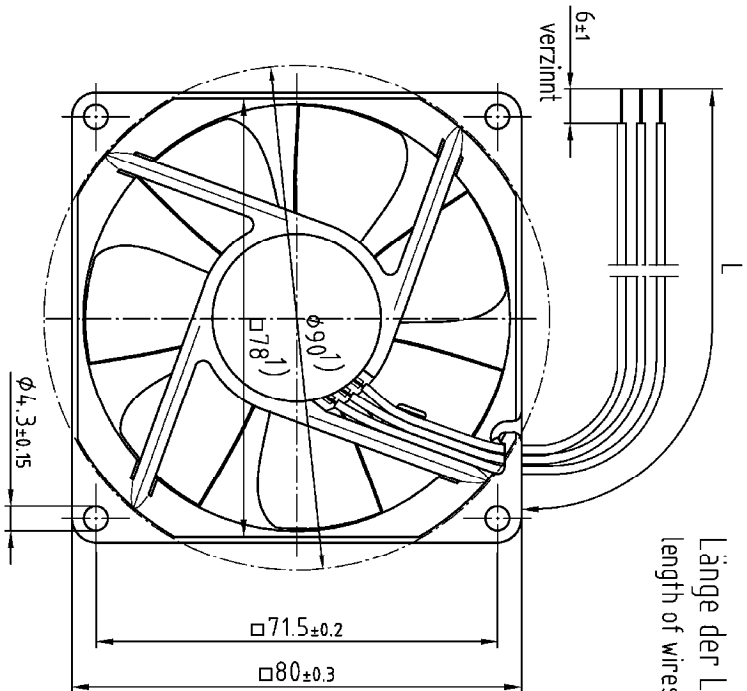

Länge der Litze s. Spezifikation  
length of wires see design specification

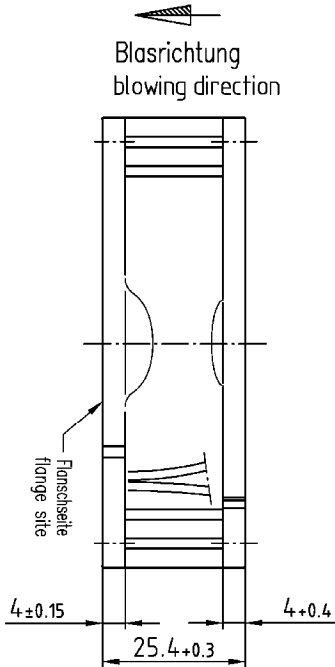

1) Maße für Montagewand

- Axialspiel bei  
- Kugellagerung (K): 0 (mit Federausgleich)  
- Gleitlagerung (G): 0.1 - 0.9

1) dimensions for assembly wall

- axial clearance by  
- ball bearing (K): 0 (with spring compensation)  
- sleeve bearing (G): 0.1 - 0.9

SAP-Status/State		Artik.-Nr./Change-No.		eblmpapst		Verstärk./Material		Volumen/Volume (cm <sup>3</sup> )	
Handl.-Spezial-Version		CAD-Umgebung/ Datei/Date		CAD-Entwurf/Name				Gewicht/Mass (g)	
Toleranz/Tolerances		Beart./ Drawn		Artikel/Title					
		Gepr./ Checked							
		Freig./ Released							
Allgemeinbezeichnungen/Gen. tolerances		Zdng.-Nr./ Drawing-No.:		eblmpapst		Ers./Zdng./Replaces:			
				eblmpapst St. Georgen GmbH & Co. KG		Detailtyp./Type of Document		Teildokument (Blatt)/Page	
						Inhalt/Content		Formal/Status	
						Massstab/Scale			