

Product Data Sheet 8312 N/2HP

**ebmpapst**

The engineer's choice



**8312 N/2HP****INDEX**

<b>1</b>	<b>General</b> .....	<b>3</b>
<b>2</b>	<b>Mechanics</b> .....	<b>3</b>
2.1	General .....	3
2.2	Connections .....	3
<b>3</b>	<b>Operating Data</b> .....	<b>5</b>
3.1	Electrical Interface - Input .....	5
3.2	Electrical Operating Data .....	6
3.3	Electrical Interface - Output .....	7
3.4	Electrical Features .....	7
3.5	Aerodynamics .....	9
3.6	Sound Data .....	11
<b>4</b>	<b>Environment</b> .....	<b>11</b>
4.1	General .....	11
4.2	Climatic Requirements .....	11
<b>5</b>	<b>Safety</b> .....	<b>12</b>
5.1	Electrical Safety .....	12
5.2	Approval Tests .....	12
<b>6</b>	<b>Reliability</b> .....	<b>12</b>
6.1	General .....	12

**1 General**

Fan type	Fan	
Rotating direction looking at rotor	Counterclockwise	
Airflow direction	Air outlet over struts	
Bearing system	Ball bearing	
Mounting position - shaft	Any	

**2 Mechanics****2.1 General**

Width	80,0 mm	
Height	80,0 mm	
Depth	32 mm	
Mass	0,1 kg	
Housing material	Plastic	
Impeller material	Plastic	
Max. torque when mounted across both mounting flanges Screw size	Wire outlet corner: 100 Ncm Remaining corners: 100 Ncm ISO 4762 - M4 degreased, without an additional brace and without washer	

**2.2 Connections**

Electrical connection	Wires	
Lead wire length	L = 310 mm	
Tolerance	+ - 10,0 mm	

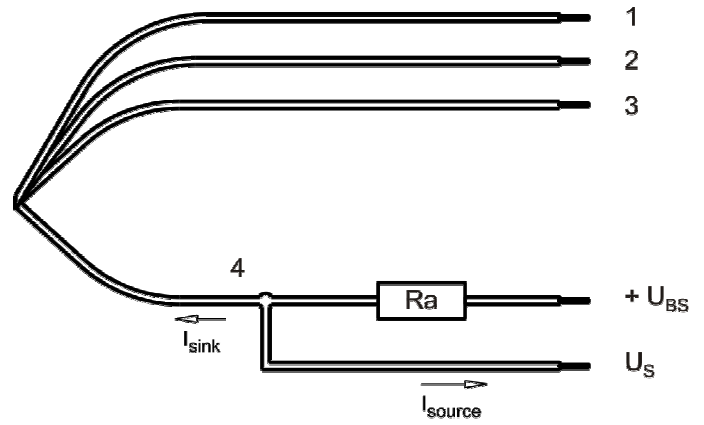

Wire	Color	Operation	Wire size	Insulation diameter
1	red	+ UB	AWG 26	1,35 mm
2	blue	- GND	AWG 26	1,35 mm
3	violet	PWM	AWG 26	1,35 mm
4	white	Tacho	AWG 26	1,35 mm

### 3 Operating Data

#### 3.1 Electrical Interface - Input

Control input	PWM
---------------	-----

#### Features

Input type	Open collector / TTL	
PWM - Frequency		21 kHz - 28 kHz typical: 25 kHz
Max. voltage for logic "Low"		0,8 V
Max. voltage for logic "High"	Open circuit voltage	5,25 V
Maximum source current	short circuit current	5 mA
4 wire startup condition	PWM duty cycle	> 25 %
4 wire operation condition after startup	PWM duty cycle	15 % - 100 %
PWM not applicable	PWM n.a.	0 % - 14 %
Shutdown condition	PWM duty cycle	< 1 %
Typical time until warm restart	After shutdown by PWM	11,8 s

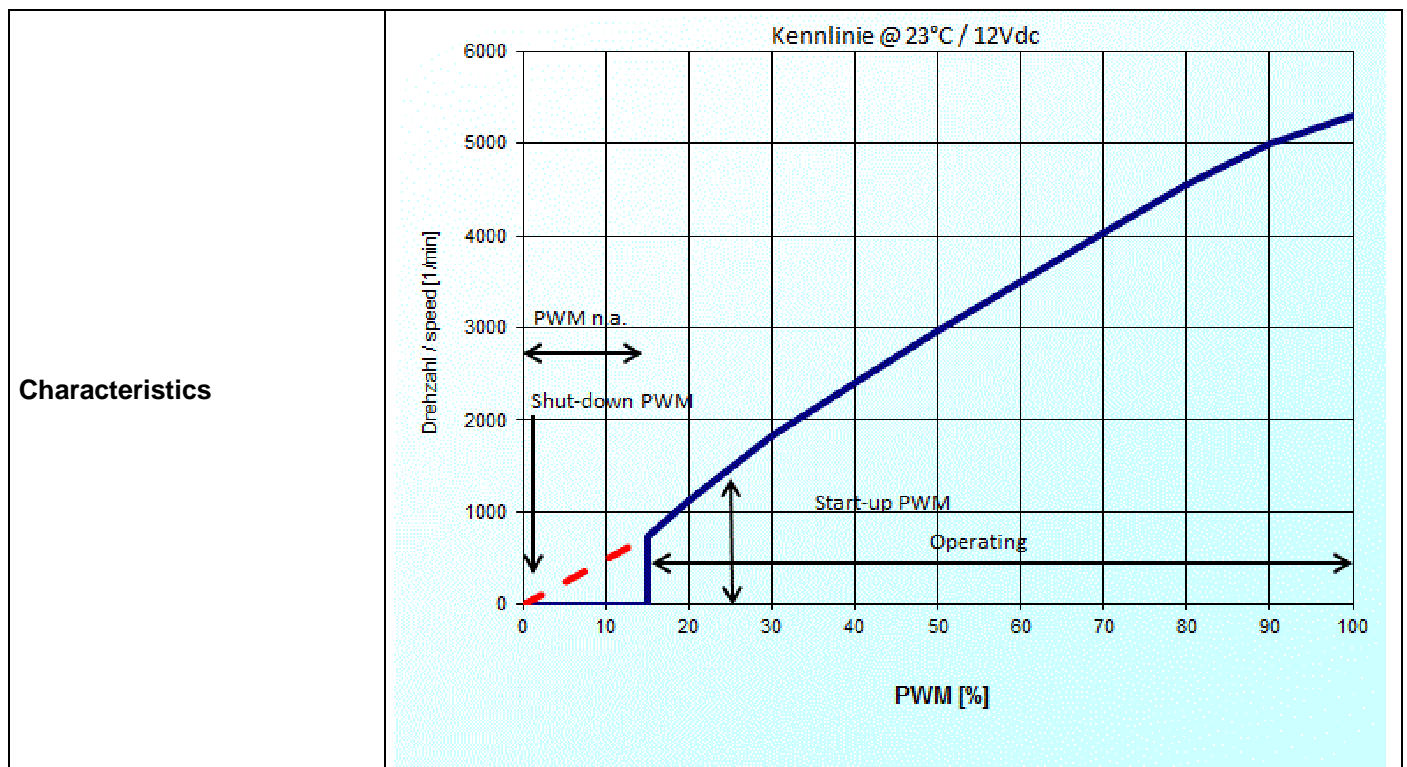

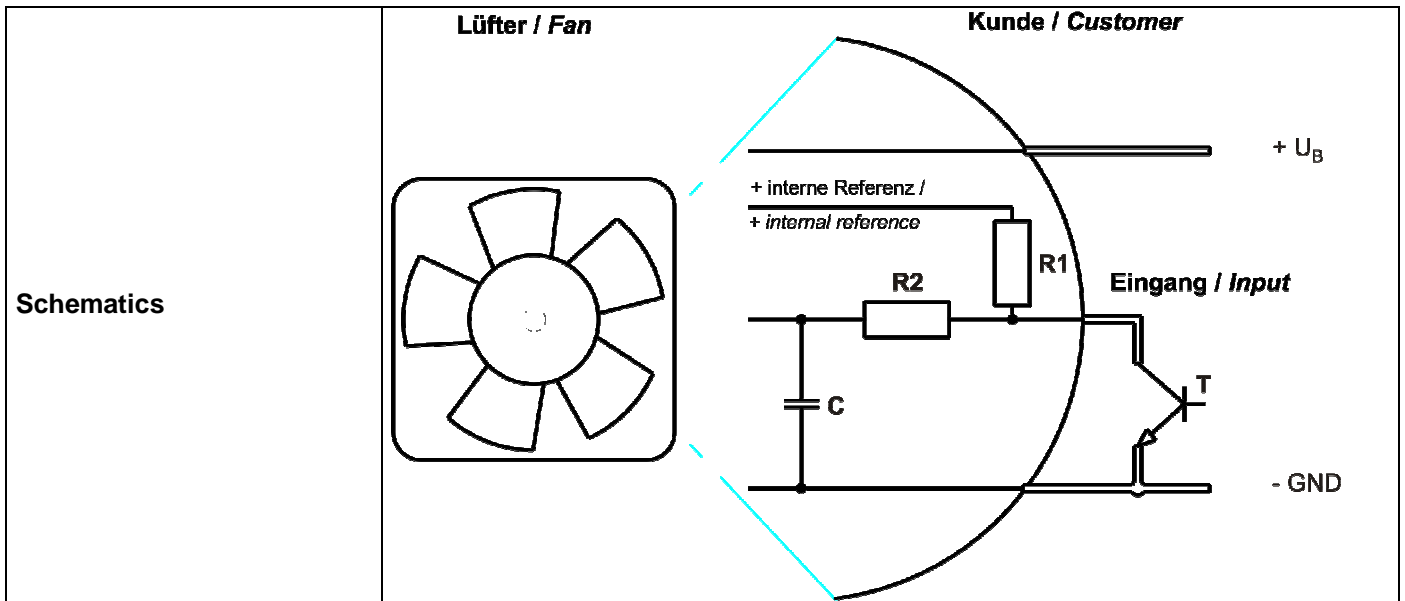

### 3.2 Electrical Operating Data

Measurement conditions: Normal air density = 1,2 kg/m<sup>3</sup>; Temperature 23°C +/- 3°C; Motor axis horizontal; warm-up time before measuring 5 minutes (unless otherwise specified). In the intake and outlet area should not be any solid obstruction within 0,5 m.

$\Delta p = 0$ : corresp. to free air flow (see chapter aerodynamics)  
 I: corresp. to arithm. mean current value

Name	Condition
PWM 0001	PWM: 100 %;

Features	Condition	Symbol	Values		
Voltage range		U	10,8 V		15 V
Nominal voltage		$U_N$		12 V	
Power consumption	$\Delta p = 0$	P	3,1 W	4 W	4,7 W
Tolerance	PWM 0010		+/- 17,5 %	+/- 12,5 %	+/- 15 %
Current consumption	$\Delta p = 0$	I	287 mA	330 mA	356 mA
Tolerance	PWM 0010		+/- 17,5 %	+/- 12,5 %	+/- 15 %
Speed	$\Delta p = 0$	n	4.680 1/min	5.300 1/min	6.300 1/min
Tolerance	PWM 0010		+/- 12,5 %	+/- 7,5 %	+/- 10 %
Starting current consumption				1.700 mA	

### 3.3 Electrical Interface - Output

Tacho type	/2 (open collector)
------------	---------------------

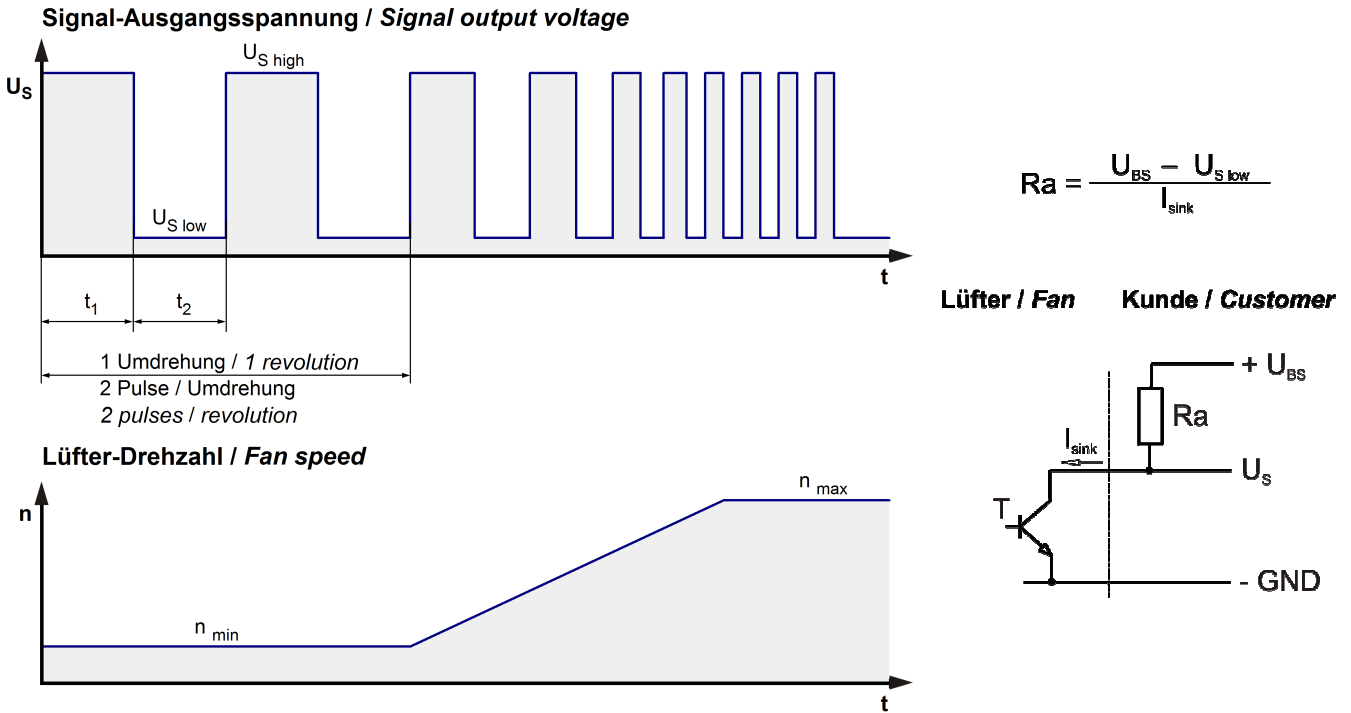

Features	Note	Values
Tacho operating voltage	$U_{BS}$	$\leq 30\text{ V}$
Tacho signal Low	$U_{S\ low}$	$\leq 0,4\text{ V}$
Tacho signal High	$U_{S\ high}$	$\leq 30\text{ V}$
Maximum sink current	$I_{sink}$	$\leq 4\text{ mA}$
Maximum source current		$0\text{ mA}$
External resistor	External resistor Ra from UBS to US required. All voltages measured to GND.	
Tacho frequency	$(2 \times n) / 60$	
Tacho isolated from motor	No	
Slew rate		$\Rightarrow 0,5\text{ V/us}$

n = revolutions per minute (1/min)

### 3.4 Electrical Features

Electronic function	None	
Reversed polarity protection	Rectifying diode	
Max. residual current at $U_N$	$I_F \leq 500\text{ uA}$	
Locked rotor protection	Auto restart	
Locked rotor current at $U_N$	$I_{block}$ approx. $1.700\text{ mA}$	
Clock signal at locked rotor	$t_3 / t_4$ typical: $0,16\text{ s} / 11,8\text{ s}$	

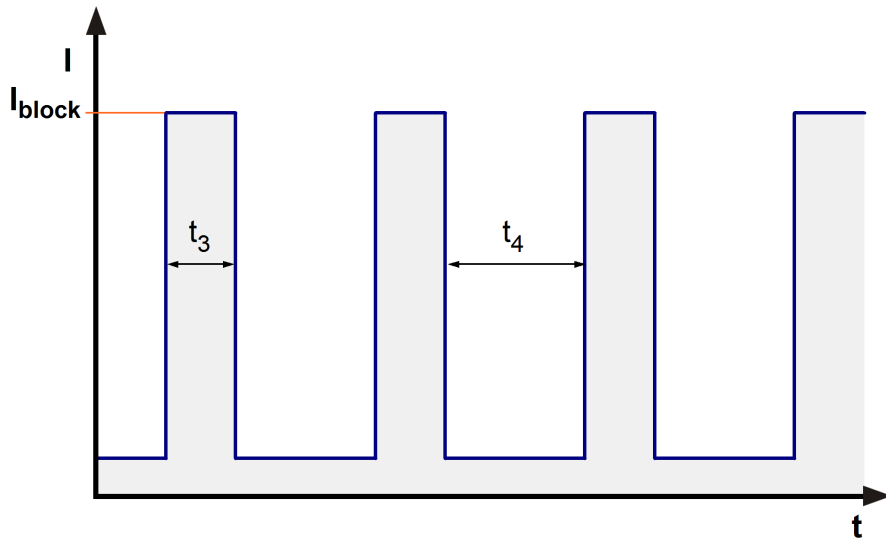



### 3.5 Aerodynamics

Measurement conditions:

Measured with a double chamber intake rig acc. to DIN EN ISO 5801.

Normal air density = 1,2 kg/m<sup>3</sup>; Temperature 23°C +/- 3°C;

In the intake and outlet area should not be any solid obstruction within 0,5 m. Motor shaft horizontal.

The information is only valid under the specified test conditions and may be changed by the installation conditions. If there are deviations from the standard test conditions, the characteristic values must be checked under the installed conditions. Power consumption of the fan motor when operating at normal voltage is shown. Depending on the operating conditions of the application, the power input may be higher.

a.) Operation condition:

5.300 1/min at free air flow	PWM 100 %;		
Max. free-air flow ( $\Delta p = 0 / \dot{V} = \text{max.}$ )		78 m <sup>3</sup> /h	
Max. static pressure ( $\Delta p = \text{max.} / \dot{V} = 0$ )		113 Pa	

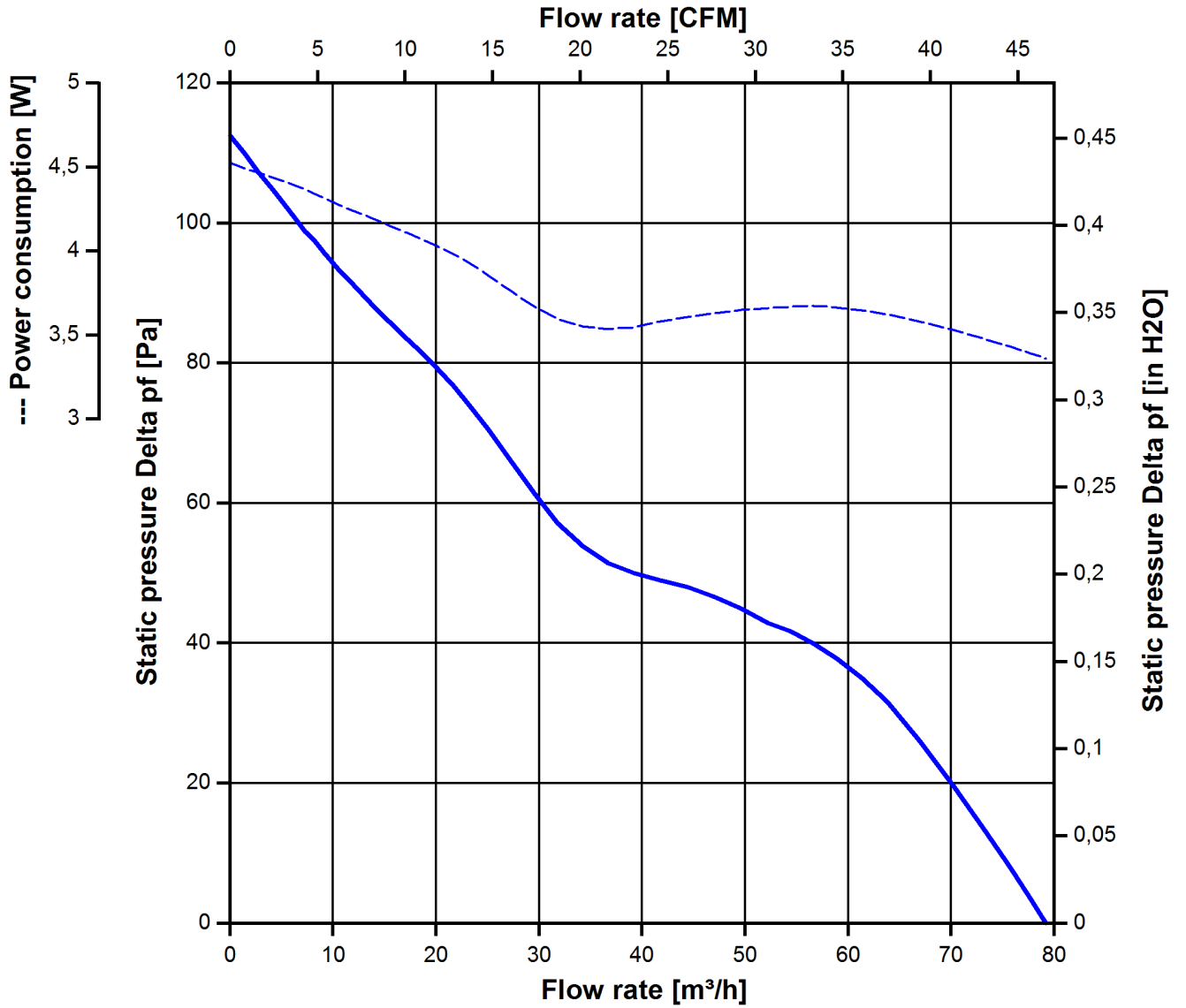

### 3.6 Sound Data

Measurement conditions: Sound pressure level: 1 meter distance between microphone and the air intake.  
 Sound power level: According to DIN 45635 Part 38 (ISO 10302)  
 Measured in a semianchoic chamber with a background noise level of  $L_p(A) < 5 \text{ dB(A)}$   
 For further measurement conditions see chapter aerodynamics.

a.) Operation condition:

5.300 1/min at free air flow	PWM 100 %;		
------------------------------	------------	--	--

Optimal operating point	52 m <sup>3</sup> /h @ 43 Pa	
Sound power level at the optimal operating point	5,3 bel(A)	
Sound pressure level at free air flow, measured in rubber bands	43 dB(A)	

## 4 Environment

### 4.1 General

Min. permitted ambient temperature TU min.	-20 °C	
Max. permitted ambient temperature TU max.	75 °C	
Min. permitted storage temperature TL min.	-40 °C	
Max. permitted storage temperature TL max.	80 °C	

### 4.2 Climatic Requirements

Humidity requirements	humid heat, constant; according to DIN EN 60068-2-78, 14 days	
Water exposure	None	
Dust requirements	None	
Salt fog requirements	None	

Permitted application area:

The product is intended for use in sheltered rooms with controlled temperature and controlled humidity. Directly exposure to water must be avoided.

Pollution degree 1 (according DIN EN 60664-1)

There is either no pollution or it occurs only dry, non-conductive pollution. The pollution has no negative impact.

Please require severity levels and specification parameters from the responsible development departments.

## 5 Safety

### 5.1 Electrical Safety

Dielectric strength DIN EN 60950 (VDE 0805) and DIN EN 60335 (VDE 0700) A.) Type test Measuring conditions: After 48h of storage at 95% R.H. and 25°C. No arcing or breakdown is allowed! All connections together to ground.	500 VAC / 1 Min.	
B.) Routine test Measuring conditions: At indoor climate. No arcing or breakdown is allowed! All connections together to ground.	850 VDC / 1 Sec.	
Isolation resistance Measuring conditions: After 48h of storage at 95% R.H. and 25°C measured with U=500 VDC for 1 min.	RI > 10 MOhm	
Clearance / creepage distance	1,0 mm / 1,2 mm	
Protection class	III	

### 5.2 Approval Tests

CE	EC Declaration of Conformity	No
EAC	Eurasian Conformity	Yes
UL	Underwriters Laboratories	Yes / UL507, Electric Fans
VDE	Association for Electrical, Electronic and Information Technologies	Yes / Approval acc. to EN 60950 (VDE 0805) - Information technology equipment
CSA	Canadian Standards Association	Yes / C22.2 No. 113 Fans and Ventilators
CCC	China Compulsory Certification	Not applicable

## 6 Reliability

### 6.1 General

Life expectancy L10 at TU = 40 °C	82.500 h	
Life expectancy L10 at TU max.	32.500 h	
Life expectancy L10 acc. to IPC 9591 at TU = 40 °C	140.000 h	

Kopie von diesem Dokument, und geben sie anderen und die Nutzung oder Kommunikation der Inhalte, sind ohne schriftliche Genehmigung von ebmpapst untersagt. Alle Rechte vorbehalten.   
 Schutzwerk nach DIN ISO 15018:2018 Beachten!   
 Refer to protection notice DIN ISO 15018:2018!

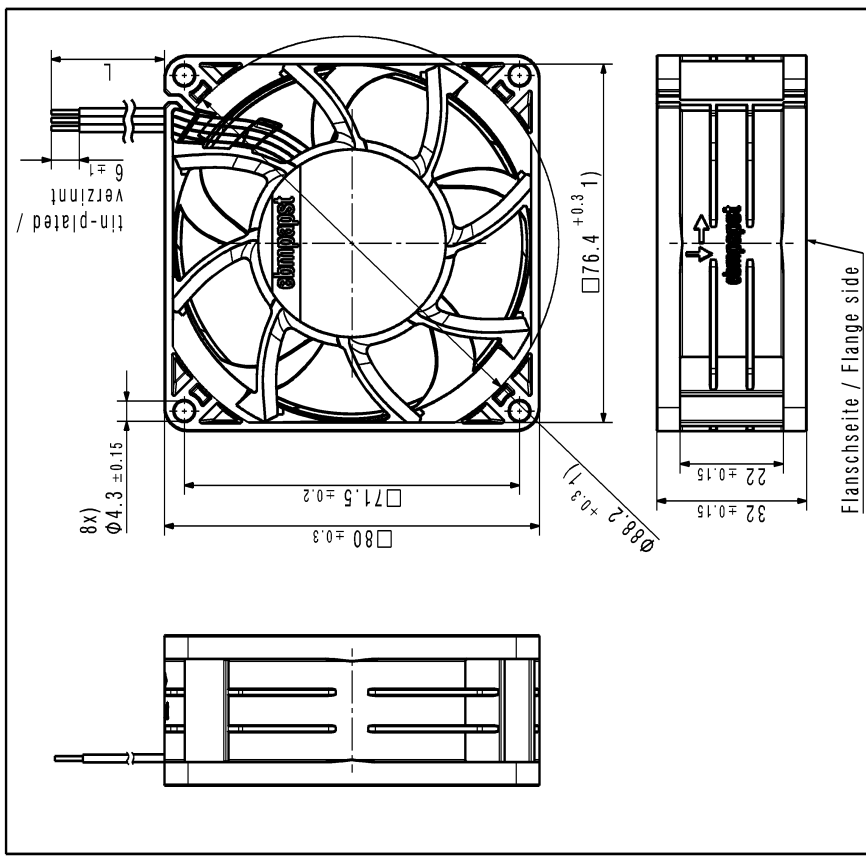

- 1) Maße für Montagewand / Dimensions for assembly wall
- Kein Axialspiel der Kugellager durch Federausgleich / no axial clearance of ball bearings due to a pre-load spring
  - Anzahl und Länge der Litzen siehe Produktspezifikation Blatt 1
- Number and length of the wires see design specification sheet 1

Dokument-Status / Document-Status		CATIA-Version / CATIA-Version	QAP-Modellname / QAP-Modellname	Revisions- / Revisions-	
		56291001_CPR00A	QAP-Modellname / QAP-Modellname	Volumen / Volume (m³):	
				Gewicht / Mass (g):	
Toleranzangabe / Tolerances		Artikel / Title:			
Haupt- / Change- / No. /		Zug- / Nr. / Drawing No.:			
Toleranzangabe / Tolerances		Ers. / Zugs. / Replaces:			
Allgemeinabmessungen / gen. Tolerances:		Format / Size:			
		Maßstab/Scale			
		A			
		ebmpapst			
		ebm-papst St. Georgen GmbH & Co KG			