

Product Data Sheet 3254 J/37H3U

**ebmpapst**

The engineer's choice



3254 J/37H3U

INDEX

<b>1</b>	<b>General</b> .....	<b>3</b>
<b>2</b>	<b>Mechanics</b> .....	<b>3</b>
2.1	General.....	3
2.2	Connections.....	3
<b>3</b>	<b>Operating Data</b> .....	<b>4</b>
3.1	Electrical Operating Data .....	4
3.2	Electrical Interface - Output.....	5
3.3	Electrical Features .....	6
3.4	Aerodynamics .....	7
3.5	Sound Data.....	8
<b>4</b>	<b>Environment</b> .....	<b>8</b>
4.1	General.....	8
4.2	Climatic Requirements .....	8
4.3	Mechanical Requirements.....	9
<b>5</b>	<b>Safety</b> .....	<b>10</b>
5.1	Electrical Safety .....	10
5.2	Approval Tests.....	10
<b>6</b>	<b>Reliability</b> .....	<b>10</b>
6.1	General.....	10

## 1 General

Fan type	Fan	
Rotating direction looking at rotor	Clockwise	
Airflow direction	Air outlet over struts	
Bearing system	Ball bearing	
Mounting position - shaft	Any	

## 2 Mechanics

### 2.1 General

Width	92,0 mm	
Height	92,0 mm	
Depth	38,0 mm	
Mass	0,25 kg	
Housing material	Plastic	
Impeller material	Plastic	
Max. torque when mounted across both mounting flanges	Wire outlet corner: 50 Ncm Remaining corners: 110 Ncm	
Screw size	ISO 4762 - M4 degreased, without an additional brace and without washer	

### 2.2 Connections

Electrical connection	Cable - Plug	
Lead wire length	See drawing	
Tolerance		
Plug	See drawing	
Contact	See drawing	

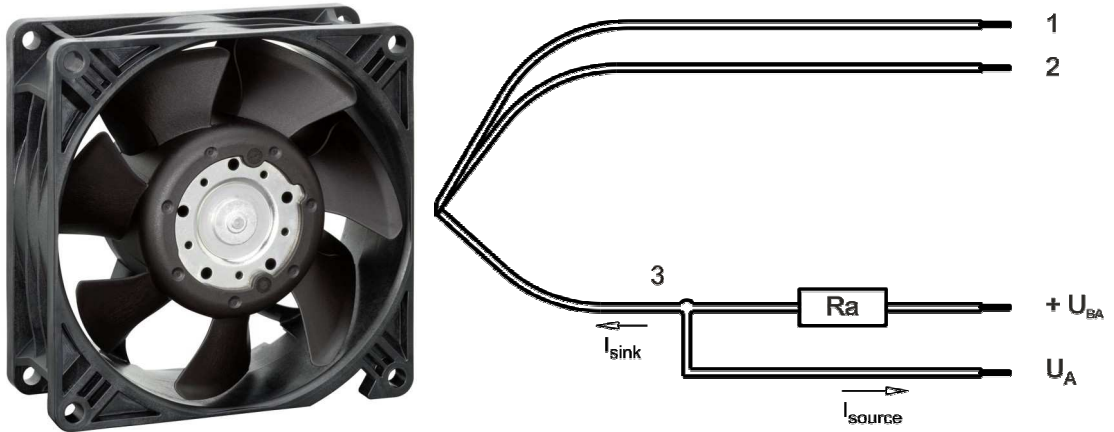

Wire	Color	Operation	Plug connection	Wire size	Insulation diameter
1	white	+ UB	Pin 2		1,27 mm
2	blue	- GND	Pin 3		1,27 mm
3	black	Tacho	Pin 4		1,27 mm

### 3 Operating Data

#### 3.1 Electrical Operating Data

Measurement conditions: Normal air density = 1,2 kg/m<sup>3</sup>; Temperature 23°C +/- 3°C; Motor axis horizontal; warm-up time before measuring 5 minutes (unless otherwise specified). In the intake and outlet area should not be any solid obstruction within 0,5 m.

$\Delta p = 0$ : corresp. to free air flow (see chapter aerodynamics)  
I: corresp. to arithm. mean current value

Features	Condition	Symbol	Values		
Voltage range		U	14 V		26,4 V
Nominal voltage		$U_N$		24 V	
Power consumption	$\Delta p = 0$	P	12 W	35 W	41 W
Tolerance	0010		+/- 20 %	+/- 15 %	+/- 15 %
Current consumption	$\Delta p = 0$	I	860 mA	1.450 mA	1.550 mA
Tolerance	0010		+/- 20 %	+/- 15 %	+/- 20 %
Speed	$\Delta p = 0$	n	5.100 1/min	7.450 1/min	7.900 1/min
Tolerance	0010		+/- 15 %	+/- 10 %	+/- 15 %
Starting current consumption				<= 3.100 mA	

### 3.2 Electrical Interface - Output

#### Signal-Ausgangsspannung / Signal output voltage

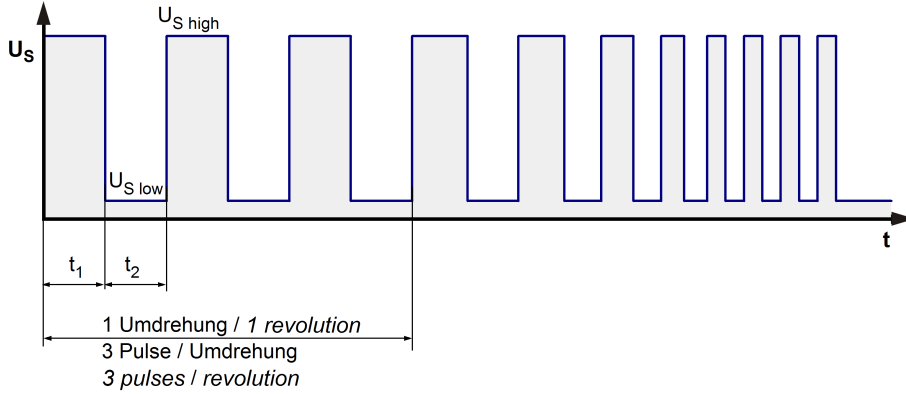

$$R_a = \frac{U_{BS} - U_{S\ low}}{I_{sink}}$$

Lüfter / Fan      Kunde / Customer

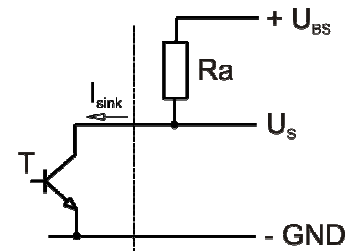

#### Lüfter-Drehzahl / Fan speed

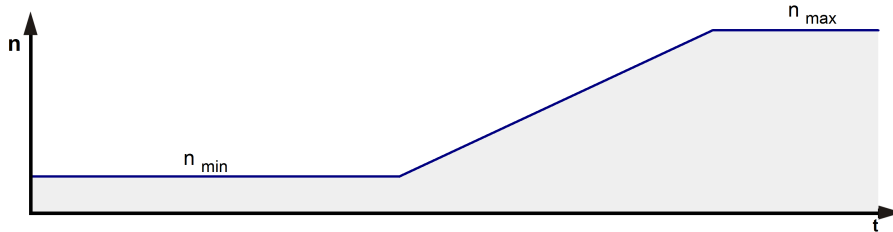

Maximum sink current	$I_{sink}$	4 mA
External resistor	External resistor $R_a$ from $U_{BS}$ to $U_S$ required. All voltages measured to GND.	
Tacho frequency	$(3 \times n) / 60$	
Tacho isolated from motor	No	
Slew rate		=> 0,5 V/us

$n$  = revolutions per minute (1/min)

Alarm type	/37 (high = ok, open collector inverse)
------------	---

$$R_a = \frac{U_{BA} - U_{A\text{low}}}{I_{\text{sink}}}$$

**Lüfter / Fan      Kunde / Customer**

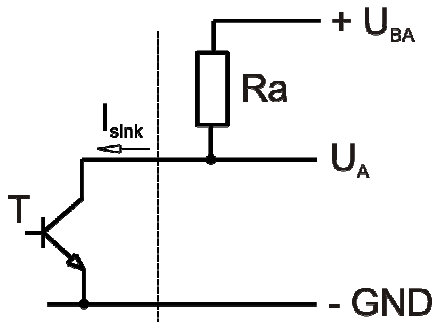

Features	Note	Values
Alarm operating voltage	$U_{BA}$	30 V
Alarm signal Low	$U_{A\text{low}}$	$I_{\text{sink}}: 2 \text{ mA}$ $\leq 0,4 \text{ V}$
Alarm signal High	$U_{A\text{high}}$	$I_{\text{source}}: 0 \text{ mA}$ 60 V
Maximum sink current	$I_{\text{sink}}$	$\leq 10 \text{ mA}$
External resistor	External resistor $R_a$ from $U_{BA}$ to $U_A$ required. All voltage measured to GND.	
Alarm start-up delay time	$t_6$	$\leq 1 \text{ s}$
Alarm trip speed limit	$n_G$	0 1/min

**3.3 Electrical Features**

Electronic function	Speed-Controlled	
Reversed polarity protection	Rectifying diode	
Max. residual current at $U_N$	$I_F \leq 200 \text{ }\mu\text{A}$	
Locked rotor protection	Auto restart	
Locked rotor current at $U_N$	$I_{\text{block}}$ approx. 3.600 mA	
Clock signal at locked rotor	$t_3 / t_4$ typical: 1 s / 9 s	

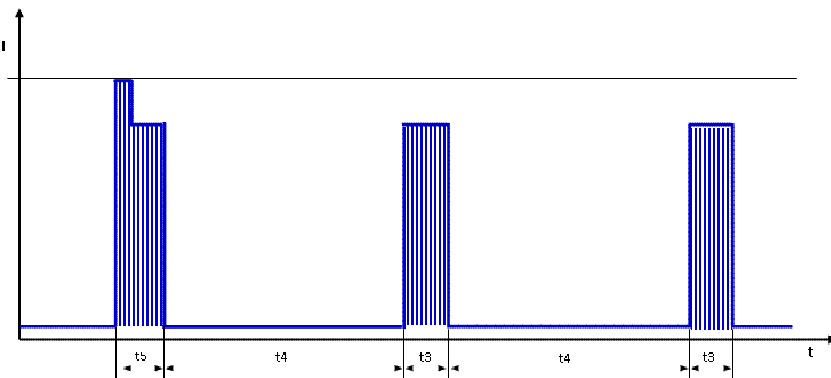

First pulse  $t_5$  typical 1,6s (1,3 .. 1,9s) followed by  $t_4$ . Afterwards cyclical  $t_3/t_4$ .

### 3.4 Aerodynamics

Measurement conditions:

Measured with a double chamber intake rig acc. to DIN EN ISO 5801.

Normal air density = 1,2 kg/m<sup>3</sup>; Temperature 23°C +/- 3°C;

In the intake and outlet area should not be any solid obstruction within 0,5 m. Motor shaft horizontal.

The information is only valid under the specified test conditions and may be changed by the installation conditions. If there are deviations from the standard test conditions, the characteristic values must be checked under the installed conditions.

a.) Operation condition:

7.450 1/min at free air flow

Max. free-air flow ( $\Delta p = 0 / \dot{V} = \max.$ )	270,0 m <sup>3</sup> /h	
Max. static pressure ( $\Delta p = \max. / \dot{V} = 0$ )	370 Pa	

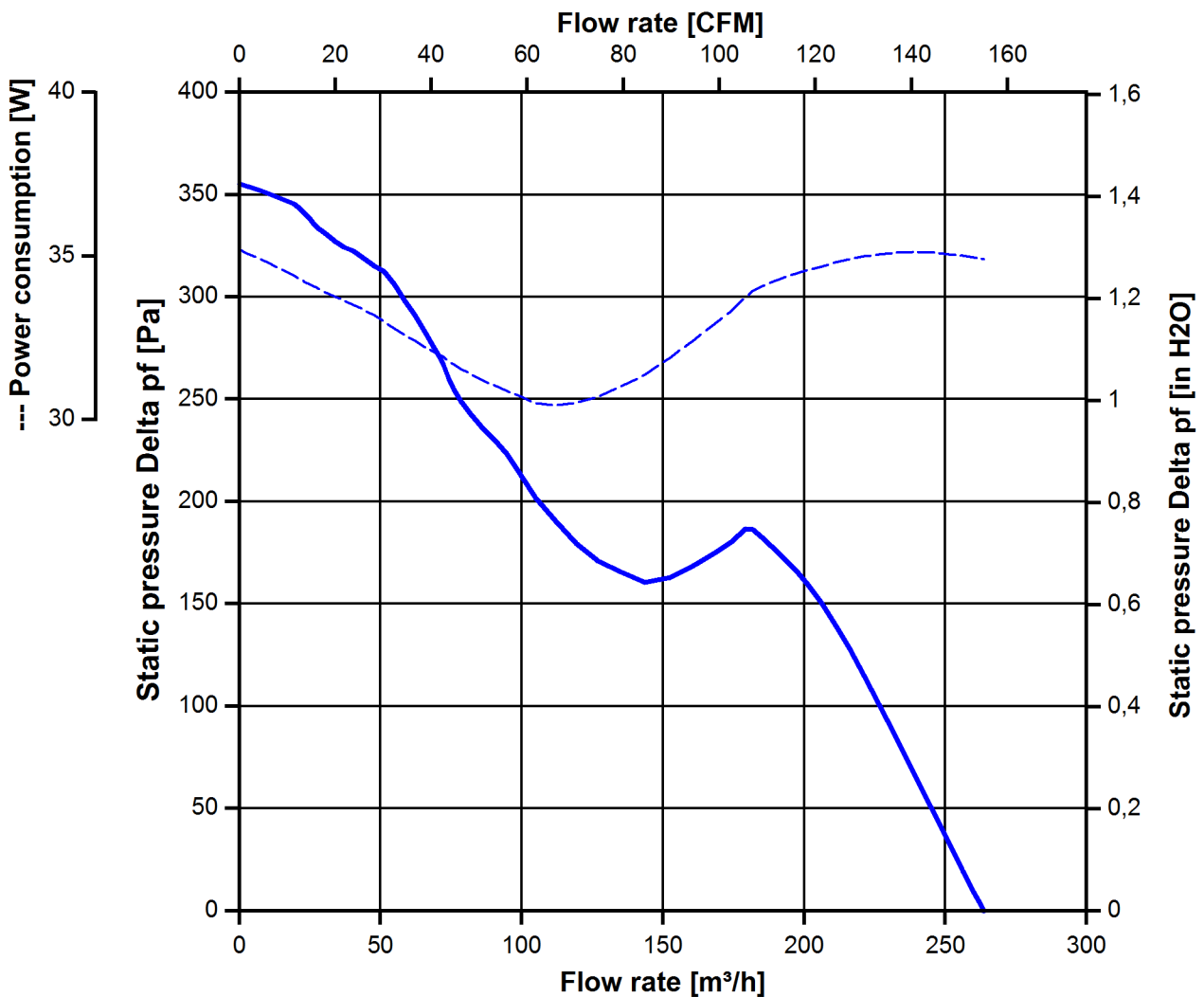

### 3.5 Sound Data

Measurement conditions: Sound pressure level: 1 meter distance between microphone and the air intake.  
 Sound power level: Acc. to DIN 45635 part 38 (ISO 10302)  
 Measured in a semianchoic chamber with a background noise level of  $L_p(A) < 5 \text{ dB(A)}$   
 For further measurement conditions see chapter aerodynamics.

a.) Operation condition:

7.450 1/min at free air flow		
Optimal operating point	191,0 m <sup>3</sup> /h @ 176 Pa	
Sound power level at the optimal operating point	7,6 bel(A)	
Sound pressure level at free air flow, measured in rubber bands	64,0 dB(A)	

## 4 Environment

### 4.1 General

Min. permitted ambient temperature TU min.	-20 °C	
Max. permitted ambient temperature TU max.	70 °C	
Min. permitted storage temperature TL min.	-40 °C	
Max. permitted storage temperature TL max.	85 °C	

### 4.2 Climatic Requirements

IP-protection type (certified)	IP 68 (for fan only, not for connector if applicable) **)	
Humidity requirements	humid temperature, cyclic; according to DIN EN 60068-2-38, 10 cycle and condensation water check; according to DIN EN ISO 6270-2, 14 days	
Salt fog requirements	salt fog, cyclic, in operation; according to DIN EN 60068-2-52, 3 cycle	

Permitted application area:

The product is for the use in open and unsheltered areas. Direct exposure to water as well as saline ambient conditions are allowed provided that this does not prevent the normal operation.

Pollution degree 3 (according DIN EN 60664-1)

It occurs conductive pollution or dry non-conductive pollution which becomes conductive due to condensation.

\*\*\*) The specification of the IP protection refers to the conditions mentioned in certification of the fan. The above mentioned short description of the protection scope is not final. For detailed information of the respective protection scope and definitions, see certification as well as DIN EN 60529 (protection by housings) and ISO 20653 (for vehicles) with the letter K.

#### **Short description of the IP-protection type:**

Solid particle Protection: Dust tight.

Protection against deliberate contact: Protected against contact to hazardous parts with a wire.

Protection against water: The fan test according to IP68 (Based on IEC 60529), is conducted in non-operating mode. The fan is tested by a complete immersion in water for a period of 2h at a water-level of 1,2m. Electrical connections are not immersed since they are customer specific.



## 4.3 Mechanical Requirements

severity level	stationary use		
1	storage / transportation	Random vibration not in use IEC 60068-2-64 Frequency range / ASD  $G_{RMS}$ Axes of vibration Test duration	Random vibration 5 - 20 Hz : $1,0 \text{ m}^2 / \text{s}^3$ 20 - 500 Hz : - 3 dB / Oct 0,91 G 3 3 x 5 h
	storage / transportation	Bump not in use IEC 60068-2-29 Shock spectrum Acceleration Duration Number of bumps (+X, -X, -Y, +Y, -Z, +Z) Total bumps	Bump half sine 18 G 6 ms 100 in each direction 600
	stationary use	Random vibration in use IEC 60068-2-64 Frequency range / ASD  $G_{RMS}$ Axes of vibration Test duration	Random vibration 5 - 20 Hz : $2,0 \text{ m}^2 / \text{s}^3$ 20- 150 Hz : - 3 dB / Oct 0,83 G 3 3 x 5 h
	stationary use	Bump in use IEC 60068-2-29 Shock spectrum Acceleration Duration Number of bumps (+X, -X, -Y, +Y, -Z, +Z) Total bumps	Bump half sine 5 G 11 ms 100 in each direction 600

## 5 Safety

### 5.1 Electrical Safety

Dielectric strength DIN EN 60950 (VDE 0805) and DIN EN 60335 (VDE 0700) A.) Type test Measuring conditions: After 48h of storage at 95% R.H. and 25°C. No arcing or breakdown is allowed! All connections together to ground.	500 VAC / 1 Min.	
B.) Routine test Measuring conditions: At indoor climate. No arcing or breakdown is allowed! All connections together to ground.	850 VDC / 1 Sec.	
Isolation resistance Measuring conditions: After 48h of storage at 95% R.H. and 25°C measured with U=500 VDC for 1 min.	RI > 10 MOhm	
Clearance / creepage distance	1,0 mm / 1,2 mm	
Protection class	III	

### 5.2 Approval Tests

CE	EC Declaration of Conformity	Yes
EAC	Eurasian Conformity	Yes
UL	Underwriters Laboratories	Yes / UL507, Electric Fans
VDE	Association for Electrical, Electronic and Information Technologies	Yes / Approval acc. to EN 60950 (VDE 0805) - Information technology equipment
CSA	Canadian Standards Association	Yes / C22.2 No. 113 Fans and Ventilators
CCC	China Compulsory Certification	Not applicable

## 6 Reliability

### 6.1 General

Life expectancy L10 at TU = 40 °C	85.000 h	
Life expectancy L10 at TU max.	42.500 h	
Life expectancy L10 acc. to IPC 9591 at TU = 40 °C	142.500 h	

Kopie von allen Zeichnungen, die nicht als Entwurf oder in anderer Weise als Freigabe gekennzeichnet sind, sind nur zur Information zu verwenden. Es ist nicht zulässig, diese Zeichnungen zu kopieren, zu reproduzieren, zu verbreiten, zu verwenden oder in andere Weise zu nutzen. Die Nutzung dieser Zeichnungen ist an der Zustimmung der Erfindungshaber gebunden. In the event of the grant of a patent or the registration of a utility model or design, the holders of these rights reserve all rights. All rights are reserved for the inventor or the holder of the right of the design. It is not permitted to copy, reproduce, disseminate, use or in any way exploit these drawings without the prior consent of the inventors or holders of the rights.

Skizzenwerk nach DIN 130 1818 Zeichen 1  
Refer to production notes DIN 130 1818 Zeichen 1

