

Product Data Sheet 5318/2TDHHP

**ebmpapst**

The engineer's choice



**5318/2TDHHP****INDEX**

<b>1</b>	<b>General</b> .....	<b>3</b>
<b>2</b>	<b>Mechanics</b> .....	<b>3</b>
2.1	General .....	3
2.2	Connections .....	3
<b>3</b>	<b>Operating Data</b> .....	<b>4</b>
3.1	Electrical Interface - Input .....	4
3.2	Electrical Operating Data .....	5
3.3	Electrical Interface - Output .....	6
3.4	Electrical Features .....	6
3.5	Aerodynamics .....	8
3.6	Sound Data .....	10
<b>4</b>	<b>Environment</b> .....	<b>10</b>
4.1	General .....	10
4.2	Climatic Requirements .....	10
<b>5</b>	<b>Safety</b> .....	<b>11</b>
5.1	Electrical Safety .....	11
5.2	Approval Tests .....	11
<b>6</b>	<b>Reliability</b> .....	<b>11</b>
6.1	General .....	11

## 1 General

Fan type	Fan	
Rotating direction looking at rotor	Counterclockwise	
Airflow direction	Air intake over struts	
Bearing system	Ball bearing	
Mounting position - shaft	Any	

## 2 Mechanics

### 2.1 General

Width	140,0 mm	
Height	140,0 mm	
Depth	51,0 mm	
Mass	0,900 kg	
Housing material	Metal	
Impeller material	Plastic	
Max. torque when mounted across both mounting flanges	Wire outlet corner: 440 Ncm Remaining corners: 600 Ncm	
Screw size	ISO 4762 - M4 degreased, without an additional brace and without washer	

### 2.2 Connections

Electrical connection	Wires	
Lead wire length	L = 310 mm	
Tolerance	+ - 10,0 mm	
Tube length	S = 10 mm	
Tolerance	+ - 2,0 mm	

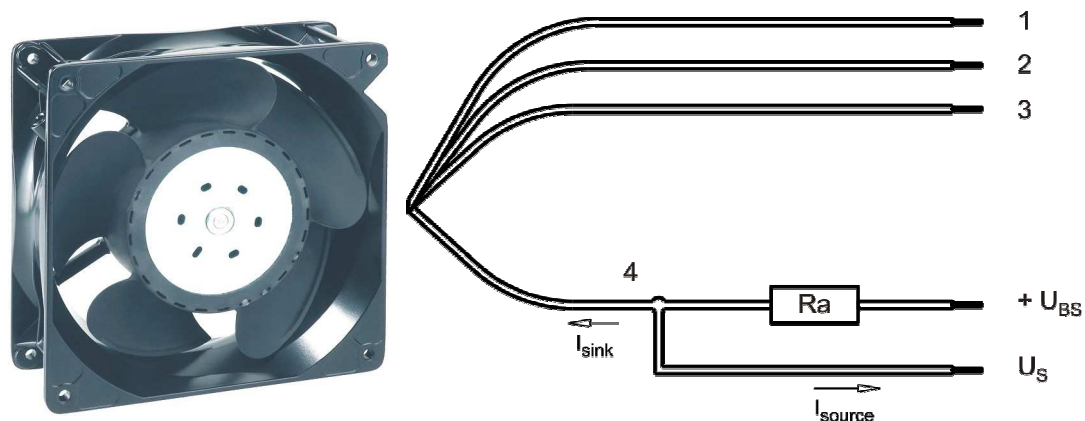

Wire	Color	Operation	Wire size	Insulation diameter
1	red	+ UB	AWG 22	1,3 mm
2	blue	- GND	AWG 22	1,3 mm
3	violet	PWM	AWG 22	1,3 mm
4	white	Tacho	AWG 22	1,3 mm

The auxiliaries shown on the schematic diagram (which are required for the intended use) are not part of our delivery.

### 3 Operating Data

#### 3.1 Electrical Interface - Input

Control input	PWM
---------------	-----

#### Features

Input type	Open collector	
PWM - Frequency		1 kHz - 10 kHz typical: 2 kHz

<p><b>Characteristics</b></p>	
<p><b>Schematics</b></p>	

The shown pull-up resistor R1 to the internal reference voltage (+5V) has 4.7kOhm.

**Speed control:**

By pulse width modulation (PWM) 0...100%

Open collector in relation to signal-ground.

**Transistor requirements:**

Vce max. >= 12V; Isink max. >=5mA; Vce sat. <= 0,15V

**Information to the curve:**

0% - <=7% PWM: 0 1/min (Fan off)  
 7% PWM: 1.000 1/min (Start-up, comming from 0% PWM)  
 7% - 10 % PWM: 1.000 1/min (corresponding to min. speed)  
 10% - 90% PWM: linear increasing curve  
 90% - 100% PWM: 7.000 1/min (corresp. to max. fan speed)  
 5% PWM: 800 1/min bzw. 0 1/min (Fan turns off, comming from 100% PWM)

**3.2 Electrical Operating Data**

Measurement conditions: Normal air density = 1,2 kg/m3; Temperature 23°C +/- 3°C; Motor axis horizontal; warm-up time before measuring 5 minutes (unless otherwise specified). In the intake and outlet area should not be any solid obstruction within 0,5 m.

$\Delta p = 0$ : corresp. to free air flow (see chapter aerodynamics)  
 I: corresp. to arithm. mean current value

Name	Condition
PWM 0001	PWM: 100 %; f: 2 kHz

**100% PWM or broken lead wire (open control input)**

Features	Condition	Symbol	Values		
Voltage range		U	36 V		72 V
Nominal voltage		U <sub>N</sub>		48 V	
Power consumption	$\Delta p = 0$	P	64 W	67 W	68 W
Tolerance	PWM 0010		+/- 10 %	+/- 10 %	+/- 10 %
Current consumption	$\Delta p = 0$	I	1.790 mA	1.400 mA	950 mA
Tolerance	PWM 0010		+/- 10 %	+/- 10 %	+/- 10 %
Speed	$\Delta p = 0$	n	7.000 1/min	7.000 1/min	7.000 1/min
Tolerance	PWM 0010		+/- 5 %	+/- 5 %	+/- 5 %
Starting current consumption				<= 2.500 mA	

### 3.3 Electrical Interface - Output

Tacho type	/2 (open collector)
------------	---------------------

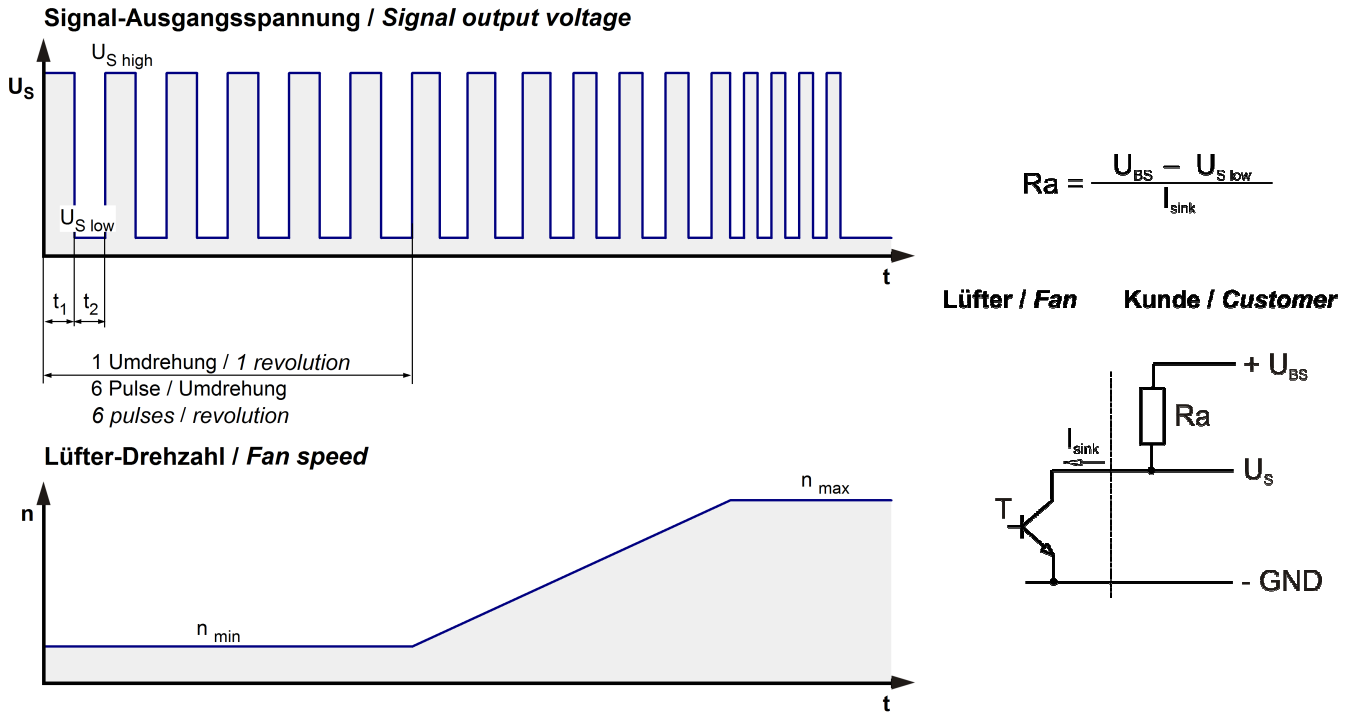

Features	Note	Values
Tacho operating voltage	$U_{BS}$	$\leq 60,0\ V$
Tacho signal Low	$U_{S\ low}$	$\leq 0,4\ V$
Tacho signal High	$U_{S\ high}$	$\leq 60,0\ V$
Maximum sink current	$I_{sink}$	$\leq 20\ mA$
Tacho frequency	$(6 \times n) / 60$	700 Hz @ 7.000 1/min
Tacho isolated from motor	No	
Slew rate		$\Rightarrow 0,5\ V/\mu s$

$n$  = revolutions per minute (1/min)

**Please note:**

At zero speed the tacho signal is at a static HIGH. It will be also HIGH when the fan is still spinning, but the speed control signal is set to zero speed already. The tacho signal is only activated after the start-up is completed.

### 3.4 Electrical Features

Electronic function	Speed-Controlled	
Reversed polarity protection	P-CH FET	
Max. residual current at $U_N$	$I_F \leq 5\ mA$	
Locked rotor protection	Auto restart	
Locked rotor current at $U_N$	$I_{block}$ approx. 2.000 mA	

Clock signal at locked rotor	$t_3 / t_4$ typical: 2,0 s / 10,0 s	
Internal fuse	Littelfuse NANO2 > Very Fast-Acting > 451/453 Series 6,3A / 125V (Art.No.: 045106.3MRL)	
Voltage control *)	Fan turns on at $U_B > 34$ V or $< 78$ V Fan turns off at $U_B < 32$ V or $> 80$ V	

\*) This fan has an undervoltage and overvoltage control circuit integrated which turns the motor off if the voltage is out of range.

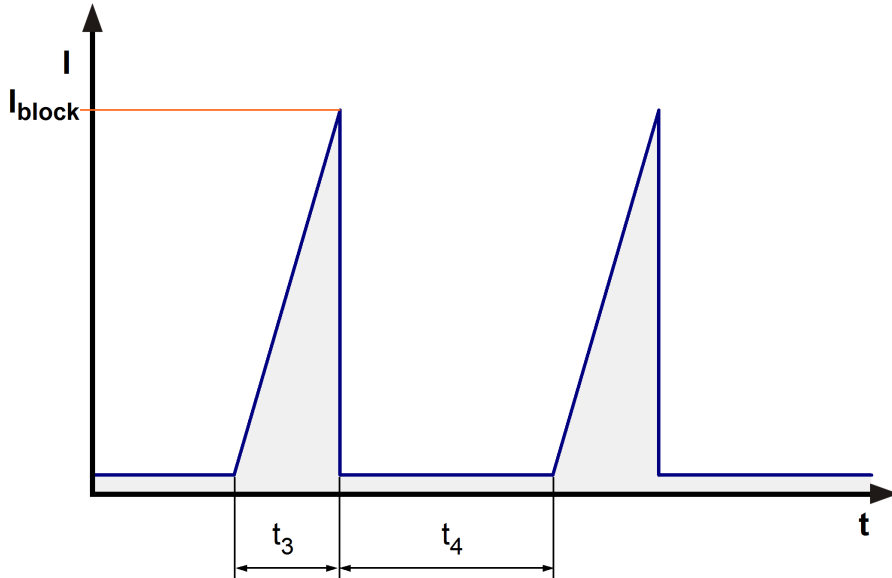

The internal electrolytic capacitors 2x220uF/75V have an inrush current limitation, the existing peak depends on ceramic capacitors.

### 3.5 Aerodynamics

Measurement conditions: Measured with a double chamber intake rig acc. to DIN EN ISO 5801.  
 Normal air density = 1,2 kg/m<sup>3</sup>; Temperature 23°C +/- 3°C;  
 In the intake and outlet area should not be any solid obstruction within 0,5 m. Motor shaft horizontal.  
 The information is only valid under the specified test conditions and may be changed by the installation conditions. If there are deviations from the standard test conditions, the characteristic values must be checked under the installed conditions.

a.) Operation condition:

7.000 1/min at free air flow	PWM 100 %; f: 2 kHz		
Max. free-air flow ( $\Delta p = 0 / \dot{V} = \text{max.}$ )		480 m <sup>3</sup> /h	
Max. static pressure ( $\Delta p = \text{max.} / \dot{V} = 0$ )		930 Pa	



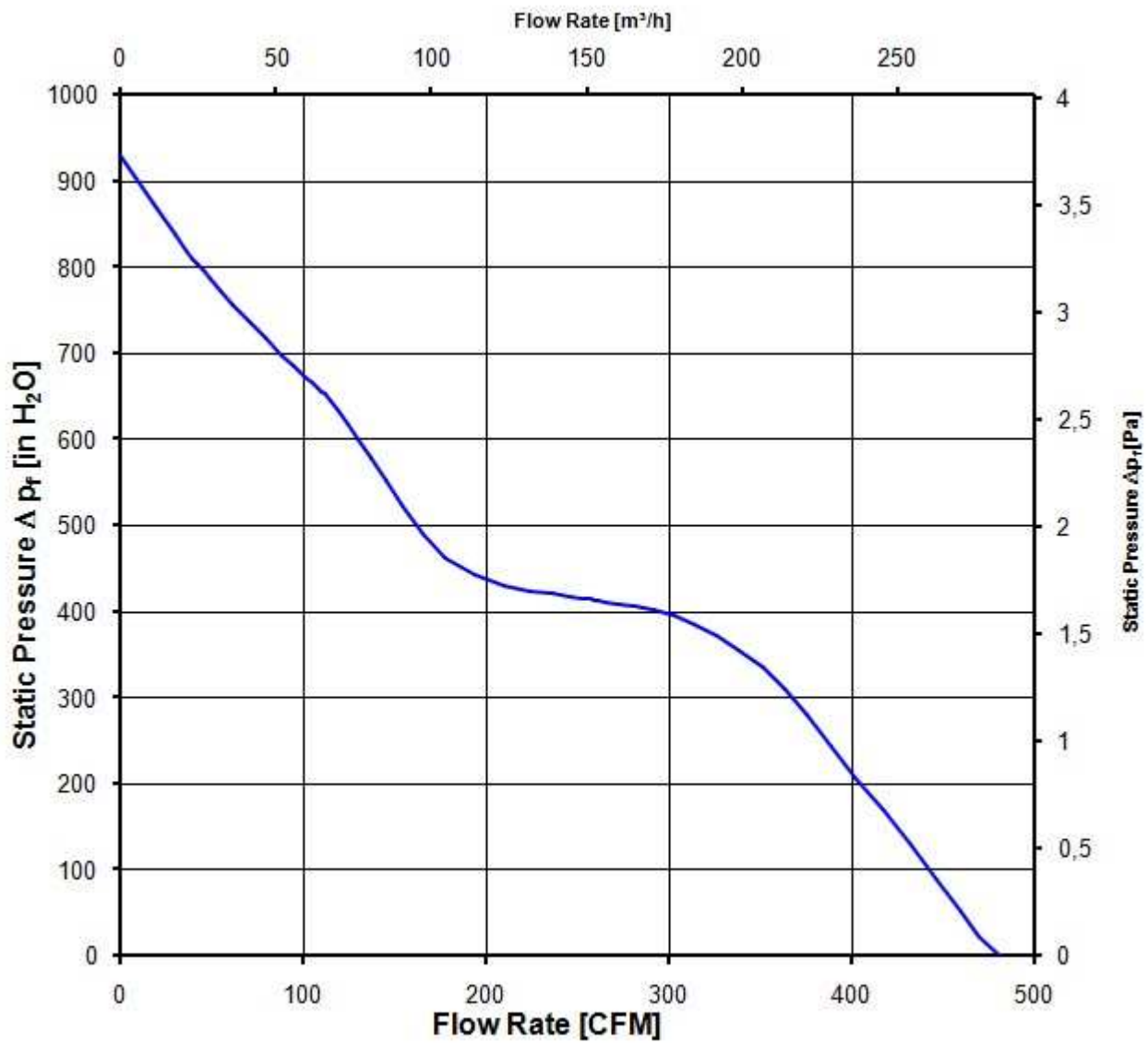

### 3.6 Sound Data

Measurement conditions: Sound pressure level: 1 meter distance between microphone and the air intake.  
 Sound power level: Acc. to DIN 45635 part 38 (ISO 10302)  
 Measured in a semianchoic chamber with a background noise level of  $L_p(A) < 5 \text{ dB(A)}$   
 For further measurement conditions see chapter aerodynamics.

a.) Operation condition:

7.000 1/min at free air flow	PWM 100 %; f: 2 kHz		
------------------------------	---------------------	--	--

Optimal operating point	320 m <sup>3</sup> /h @ 340 Pa	
Sound power level at the optimal operating point	8,2 bel(A)	
Sound pressure level at free air flow, measured in rubber bands	75,0 dB(A)	

## 4 Environment

### 4.1 General

Min. permitted ambient temperature TU min.	-20 °C	
Max. permitted ambient temperature TU max.	70 °C	
Min. permitted storage temperature TL min.	-40 °C	
Max. permitted storage temperature TL max.	80 °C	

### 4.2 Climatic Requirements

Humidity requirements	humid heat, constant; according to DIN EN 60068-2-78, 14 days	
Water exposure	None	
Dust requirements	None	
Salt fog requirements	None	

Permitted application area:

The product is intended for use in sheltered rooms with controlled temperature and controlled humidity. Directly exposure to water must be avoided.

Pollution degree 1 (according DIN EN 60664-1)

There is either no pollution or it occurs only dry, non-conductive pollution. The pollution has no negative impact.

Please require severity levels and specification parameters from the responsible development departments.

**5 Safety**

**5.1 Electrical Safety**

Dielectric strength DIN EN 60950 (VDE 0805) and DIN EN 60335 (VDE 0700) A.) Type test Measuring conditions: After 48h of storage at 95% R.H. and 25°C. No arcing or breakdown is allowed! All connections together to ground.	1000 VAC / 1 Min.	
B.) Routine test Measuring conditions: At indoor climate. No arcing or breakdown is allowed! All connections together to ground.	1700 VDC / 1 Sec.	
Isolation resistance Measuring conditions: After 48h of storage at 95% R.H. and 25°C measured with U=500 VDC for 1 min.	RI > 10 MOhm	
Clearance / creepage distance	1,0 mm / 1,5 mm	
Protection class	I	

**5.2 Approval Tests**

CE	EC Declaration of Conformity	No
EAC	Eurasian Conformity	Yes
UL	Underwriters Laboratories	Yes / UL audited by CSA according to UL507, Electric Fans
VDE	Association for Electrical, Electronic and Information Technologies	Yes / Approval acc. to EN 60950 (VDE 0805) - Information technology equipment
CSA	Canadian Standards Association	Yes / C22.2 No. 113 Fans and Ventilators
CCC	China Compulsory Certification	Yes / GB 12350 Safety Requirements for small Power Motors

The approval tests are observed to:

U approval max.:72,0 V @ TU approval max.: 70,0 °C

**6 Reliability**

**6.1 General**

Life expectancy L10 at TU = 40 °C	62.500 h	
Life expectancy L10 at TU max.	30.000 h	
Life expectancy L10 acc. to IPC 9591 at TU = 40 °C	105.000 h	

Schraube: Duo-Tapflite nach  
 screw: Duo-Tapflite according to  
 DIN 7500; CM4x8; Torx

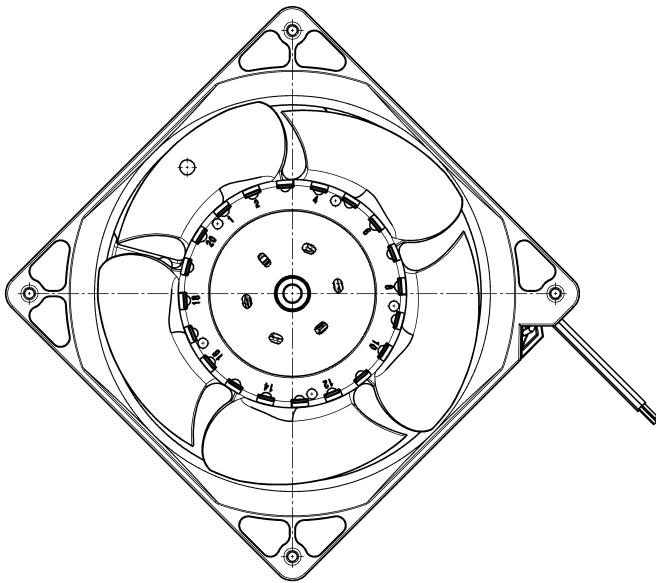
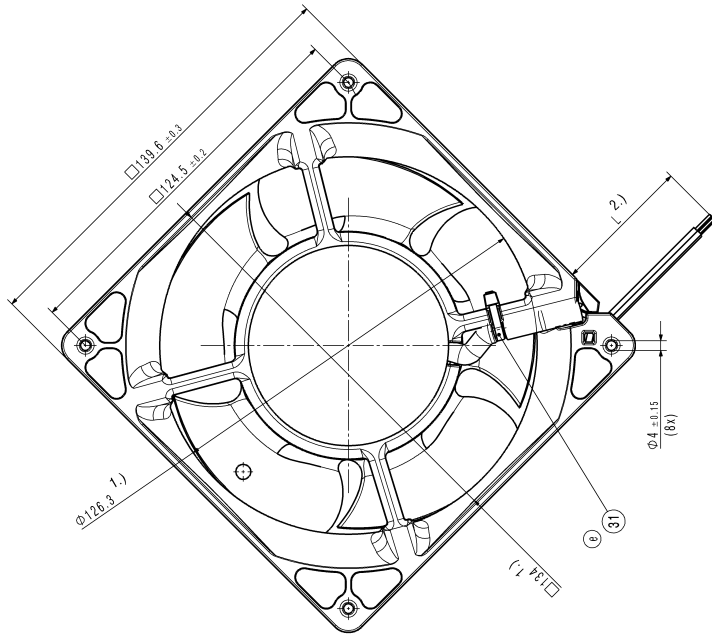
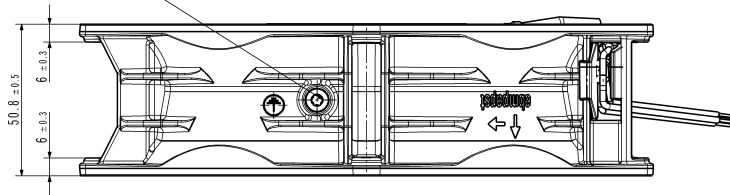

- 1.) Maße aus Montageauschnitt  
 2.) Anzahl und Länge der Litzen siehe Produktspezifikation  
 - Axialspiel der Kugellager mit Feder spielfrei gelagert  
 1.) measures of mounting cut out  
 2.) length an number of wires see product specification  
 - ball bearing without clearance by a pre-load spring

Zeichnung / Drawing 279.277.077 Blatt 01 / Sheet 01		Fertigt / Material ZLAlMgSi2 (ZL102)	
Bauelement / Part 100.000.001	Bauelement / Part 100.000.001	Zeichnung / Drawing 279.277.077	
Bauelement / Part 100.000.001	Bauelement / Part 100.000.001	Zeichnung / Drawing 279.277.077	
Bauelement / Part 100.000.001		Zeichnung / Drawing 279.277.077	
Bauelement / Part 100.000.001		Zeichnung / Drawing 279.277.077	
Bauelement / Part 100.000.001		Zeichnung / Drawing 279.277.077	
Bauelement / Part 100.000.001		Zeichnung / Drawing 279.277.077	
Bauelement / Part 100.000.001		Zeichnung / Drawing 279.277.077	
Bauelement / Part 100.000.001		Zeichnung / Drawing 279.277.077	
Bauelement / Part 100.000.001		Zeichnung / Drawing 279.277.077	
Bauelement / Part 100.000.001		Zeichnung / Drawing 279.277.077	
Bauelement / Part 100.000.001		Zeichnung / Drawing 279.277.077	
Bauelement / Part 100.000.001		Zeichnung / Drawing 279.277.077	
Bauelement / Part 100.000.001		Zeichnung / Drawing 279.277.077	