

Product Data Sheet RER160-28/56S

ebmpapst

The engineer's choice



RER160-28/56S

INDEX

1 General 3

2 Mechanics 3

 2.1 GENERAL 3

 2.2 CONNECTIONS 4

3 Operating Data 5

 3.1 ELECTRICAL OPERATING DATA 5

 3.2 ELECTRICAL FEATURES 6

 3.3 AERODYNAMICS 6

 3.4 SOUND DATA 9

4 Environment 9

 4.1 GENERAL 9

 4.2 CLIMATIC REQUIREMENTS*) 9

5 Safety 10

 5.1 ELECTRICAL SAFETY 10

 5.2 APPROVAL TESTS 10

6 Reliability 10

 6.1 GENERAL 10

1 General

Fan type	Blower without chassis with intake nozzle
Rotating direction looking at rotor	Counterclockwise
Airflow direction	Air in axially, Air out radially
Bearing system	Ball bearing
Mounting position - shaft	Any
Balancing grade	6,3

2 Mechanics**2.1 General**

Width	0,0 mm	
Height	0,0 mm	
Depth	54,0 mm	
Diameter	176,0 mm	
Mass	1,000 kg	
Housing material		
Impeller material	Mixed	

2.2 Connections

Electrical connection	Wires	
Lead wire length	L = 425,0 mm	
Tolerance	+ - 10,0 mm	
Tube length	S = 385,0 mm	
Tolerance	+ - 10,0 mm	
Wire size (AWG)	18	
Insulation diameter	1,65 mm	
Plug	See drawing	
Contact	See drawing	

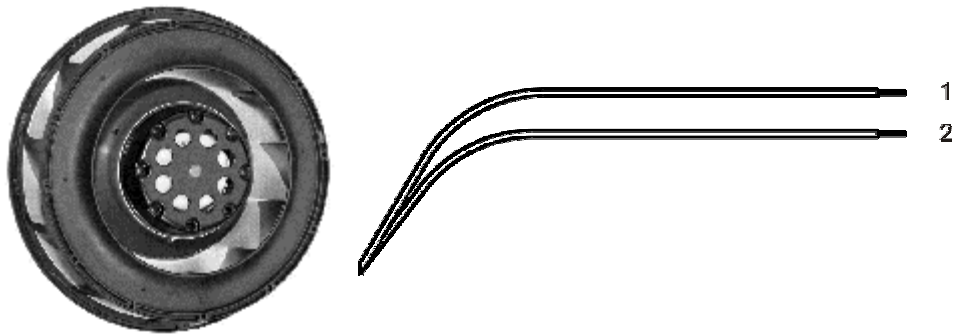

	Color	Operation
1	blue	L
2	blue	N

3 Operating Data

3.1 Electrical Operating Data

For checking purposes the electrical data can be specified without an intake nozzle / aperture plate as well. For this the data have to defined by the appropriate quality assurance.

Electrical Operating Data with Intake Nozzle (for testing purposes)

Measurement conditions: Normal air density = 1,2 kg/m³; Temperature 23°C +/- 3°C; Motor axis horizontal; warm-up time before measuring 5 minutes (unless otherwise specified).
In the intake and outlet area should not be any solid obstruction within 0,5 m.

Measurement setup:	Measured between two steel plates
Steel plate:	260 mm x 260 mm
Intake nozzle:	D: 100 mm; R: 5 mm
Distance between bottom and top plate:	55 mm
Overlapping impeller / nozzle:	2 mm

$\Delta p = 0$: corresp. to free air flow (see chapter aerodynamics)

I: corresp. to RMS line current

Features	Condition	Symbol	Values	
			50 Hz	60 Hz
Frequency	$\Delta p = 0$	f	230,0 V +/- 10,0 %	230,0 V +/- 10,0 %
Nominal voltage Tolerance	$\Delta p = 0$	U_N	45 W	46 W
Power consumption Tolerance	$\Delta p = 0$	P	+ 5,0 % - 10,0 %	+ 5,0 % - 10,0 %
Speed Tolerance	$\Delta p = 0$	n	2.850 1/min +/- 3,0 %	3.250 1/min +/- 3,0 %

3.2 Electrical Features

Locked rotor protection	Thermal circuit breaker
Locked rotor current at	

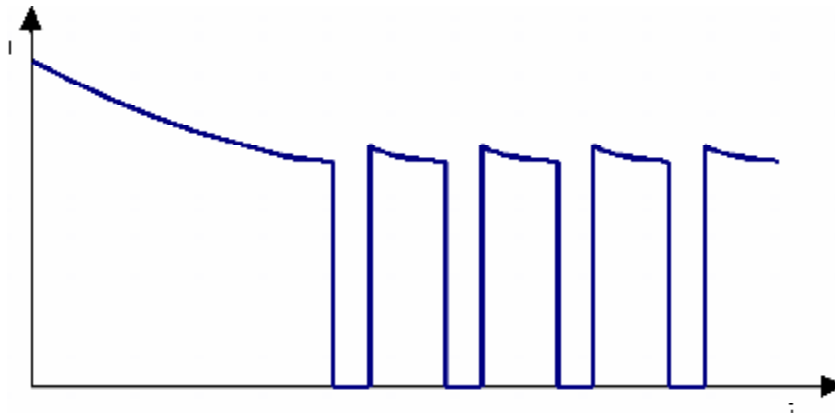

3.3 Aerodynamics

Measurement conditions: Measured with a double chamber intake rig acc. to DIN EN ISO 5801.
Normal air density = 1,2 kg/m³; Temperature 23°C +/- 3°C;
In the intake and outlet area should not be any solid obstruction within 0,5 m. Motor shaft horizontal.
The information is only valid under the specified test conditions and may be changed by the installation conditions. If there are deviations from the standard test conditions, the characteristic values must be checked under the installed conditions.

Measurement setup:	Measured between two steel plates
Steel plate:	260 mm x 260 mm
Intake nozzle:	D: 100 mm; R: 5 mm
Distance between bottom and top plate:	55 mm
Overlapping impeller / nozzle:	2 mm

a.) Operation condition:
2.850 1/min at free air flow Frequency: 50 Hz

Max. free-air flow ($\Delta p = 0 / \dot{V} = \max.$)	240,0 m ³ /h
Max. static pressure ($\Delta p = \max. / \dot{V} = 0$)	250 Pa

b.) Operation condition:
3.250 1/min at free air flow Frequency: 60 Hz

Max. free-air flow ($\Delta p = 0 / \dot{V} = \max.$)	270,0 m ³ /h
Max. static pressure ($\Delta p = \max. / \dot{V} = 0$)	350 Pa

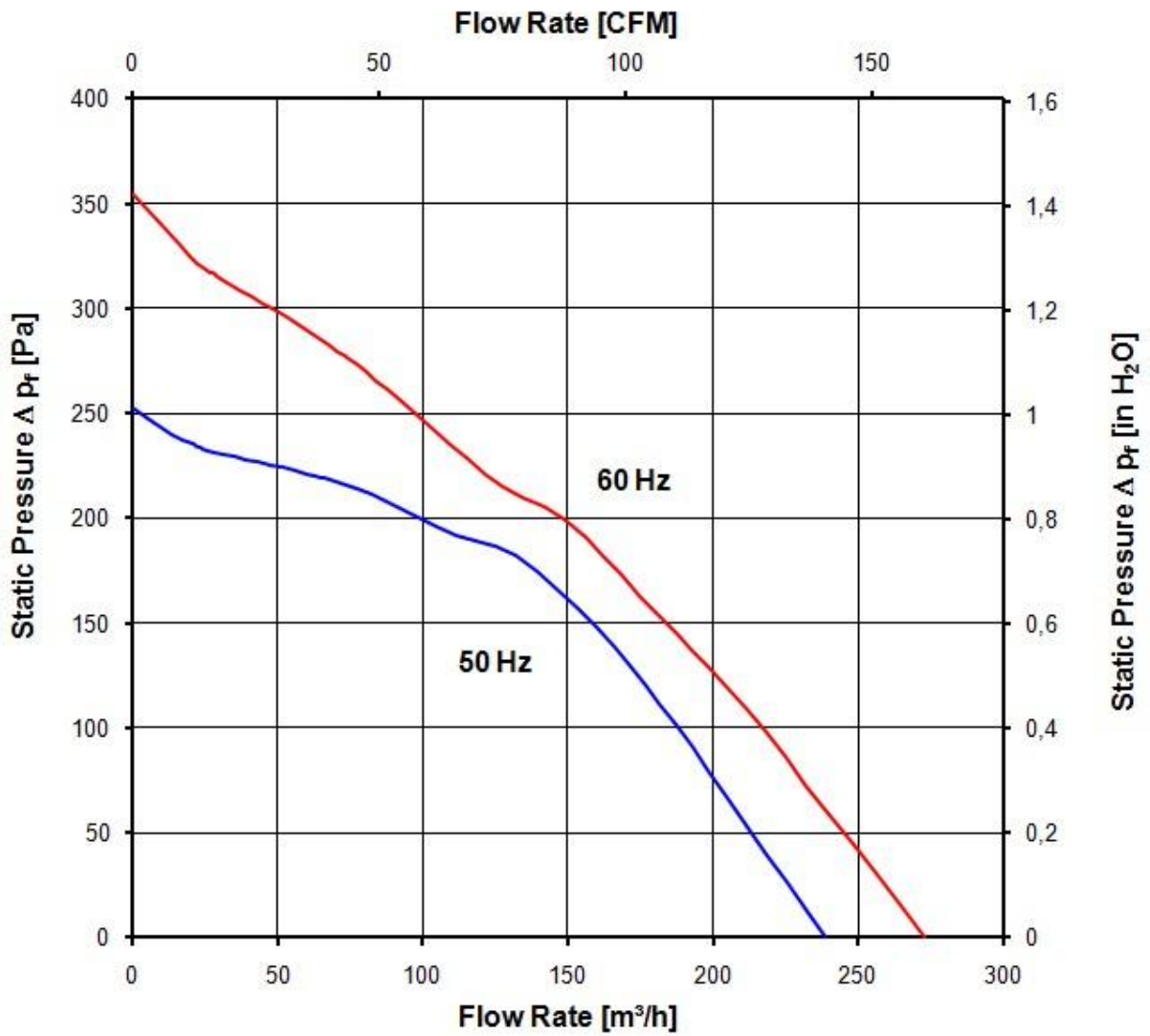

3.4 Sound Data

Measurement conditions: Sound pressure level: 1 meter distance between microphone and the air intake.
 Sound power level: Acc. to DIN 45635 part 38 (ISO 10302) Sound power level: Acc. to DIN 45635 part 38 (ISO 10302)
 Measured in a semianchoic chamber with a background noise level of $L_p(A) < 5 \text{ dB}(A)$
 For further measurement conditions see chapter aerodynamics.

a.) Operation condition:
 2.850 1/min at free air flow Frequency: 50 Hz

Optimal operating point	1,0 m ³ /h @ 215 Pa	
Sound power level at the optimal operating point	6,5 bel(A)	
Sound pressure level at free air flow, measured in rubber bands		

b.) Operation condition:
 3.250 1/min at free air flow Frequency: 60 Hz

Optimal operating point	12,0 m ³ /h @ 280 Pa	
Sound power level at the optimal operating point	6,8 bel(A)	
Sound pressure level at free air flow, measured in rubber bands		

4 Environment

4.1 General

Min. permitted ambient temperature TU min.	-30 °C / 50 Hz -30 °C / 60 Hz	
Max. permitted ambient temperature TU max.	60 °C / 50 Hz 70 °C / 60 Hz	
Min. permitted storage temperature TL min.	-40 °C	
Max. permitted storage temperature TL max.	80 °C	

4.2 Climatic Requirements*)

Humidity requirements	humid heat, constant; according to DIN EN 60068-2-78, 14 days	
Water exposure	None	
Dust requirements	None	
Salt fog requirements	None	

Permitted application area:

The product is intended for use in sheltered rooms with controlled temperature and controlled humidity. Directly exposure to water must be avoided.

Pollution degree 1 (according DIN EN 60664-1)

There is either no pollution or it occurs only dry, non-conductive pollution. The pollution has no negative impact.

5 Safety

5.1 Electrical Safety

Dielectric strength DIN EN 60950 (VDE 0805) and DIN EN 60335 (VDE 0700) A.) Type test Measuring conditions: After 48h of storage at 95% R.H. and 25°C. No arcing or breakdown is allowed! All connections together to ground. B.) Routine test Measuring conditions: At indoor climate. No arcing or breakdown is allowed! All connections together to ground.	1500 VAC / 1 Min. 1500 VAC / 1 Sec.
Isolation resistance Measuring conditions: After 48h of storage at 95% R.H. and 25°C measured with U=500 VDC for 1 min.	RI > 50 MOhm
Clearance / creepage distance	2,0 mm / 1,8 mm
Protection class	I

5.2 Approval Tests

CE	EC Declaration of Conformity	Yes
EAC	Eurasian Conformity	Yes
UL	Underwriters Laboratories	Yes / UL507, Electric Fans
VDE	Association for Electrical, Electronic and Information Technologies	Yes / Approval acc. to EN 60950 (VDE 0805) - Information technology equipment
CSA	Canadian Standards Association	Yes / C22.2 No. 113 Fans and Ventilators
CCC	China Compulsory Certification	Yes / GB 12350 Safety Requirements for small Power Motors

The approval tests are observed to:

U approval max.: 230 V / f: 60 Hz @ TU approval max.: 80 °C

6 Reliability

6.1 General

Life expectancy L10 at TU = 40 °C	30.000 h / 50 Hz 30.000 h / 60 Hz	
Life expectancy L10 at TU max.	20.000 h / 50 Hz 15.000 h / 60 Hz	

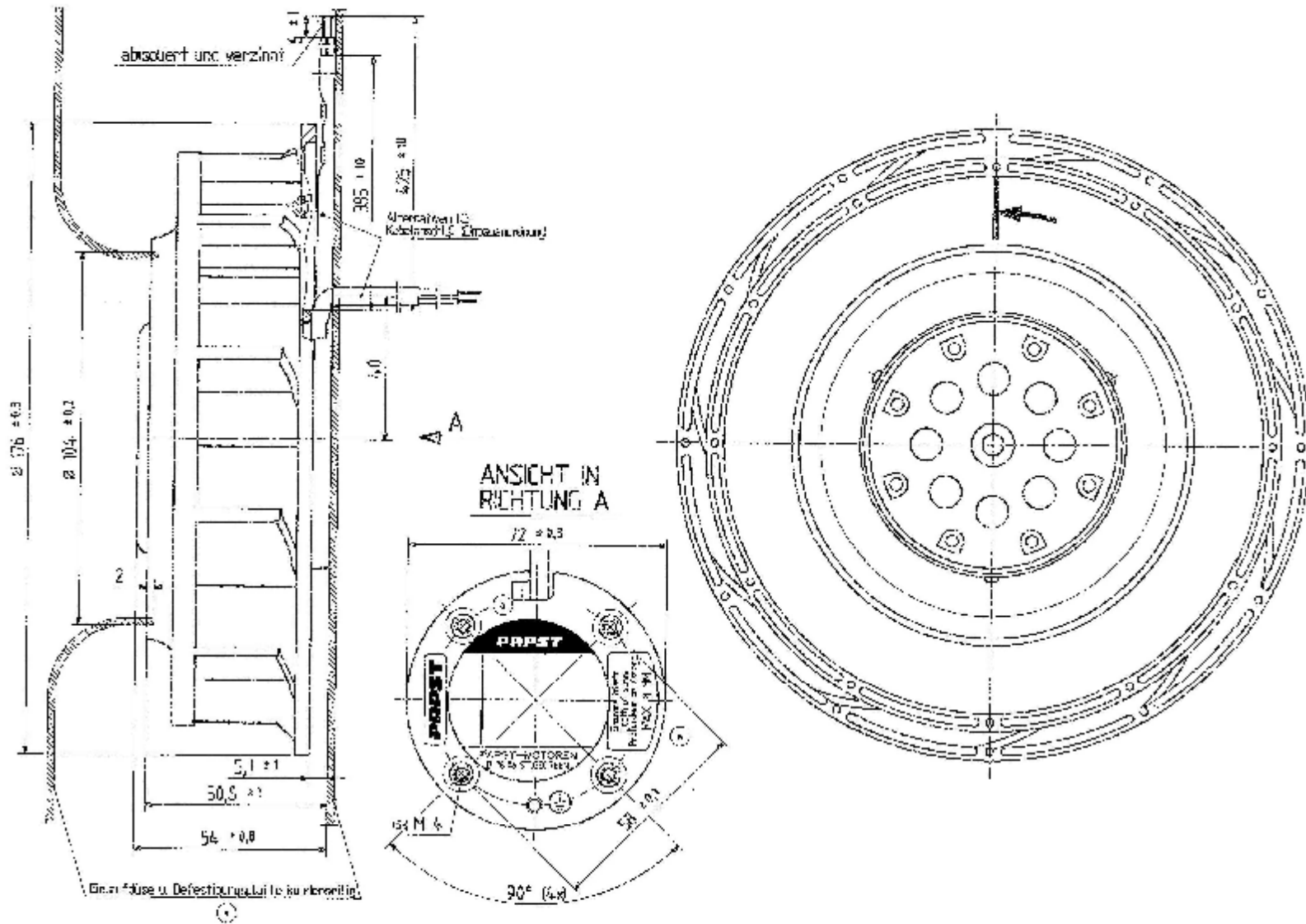

Axialspiel mit Feder spielfrei gespannt